

**WARREN
RUPP®**

Quality System
ISO9001 Certified

Environmental
Management System
ISO14001 Certified

IDEX
IDEX CORPORATION

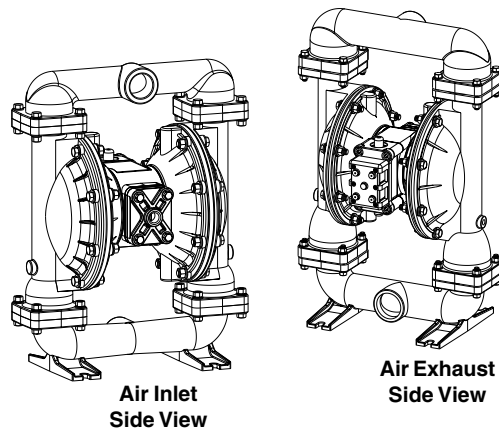

U.S. Patent #5,996,627 & 6,241,487
Other U.S. Patents Applied for



MARATHON II®

M20 Metallic Design Level I Ball Valve

Air-Powered Double-Diaphragm Pump

ENGINEERING, PERFORMANCE
& CONSTRUCTION DATA

INTAKE/DISCHARGE PIPE SIZE	CAPACITY	AIR VALVE	SOLIDS-HANDLING	HEADS UP TO	DISPLACEMENT/STROKE
2" NPT(internal) 2" BSPT Tapered (internal)	0 to 150 gallons per minute (0 to 567 liters per minute)	No-lube, no-stall design	Up to .25 in. (6mm)	125 psi or 289 ft. of water (8.6 Kg/cm ² or 86 meters)	.42 Gallon / 1.59 liter

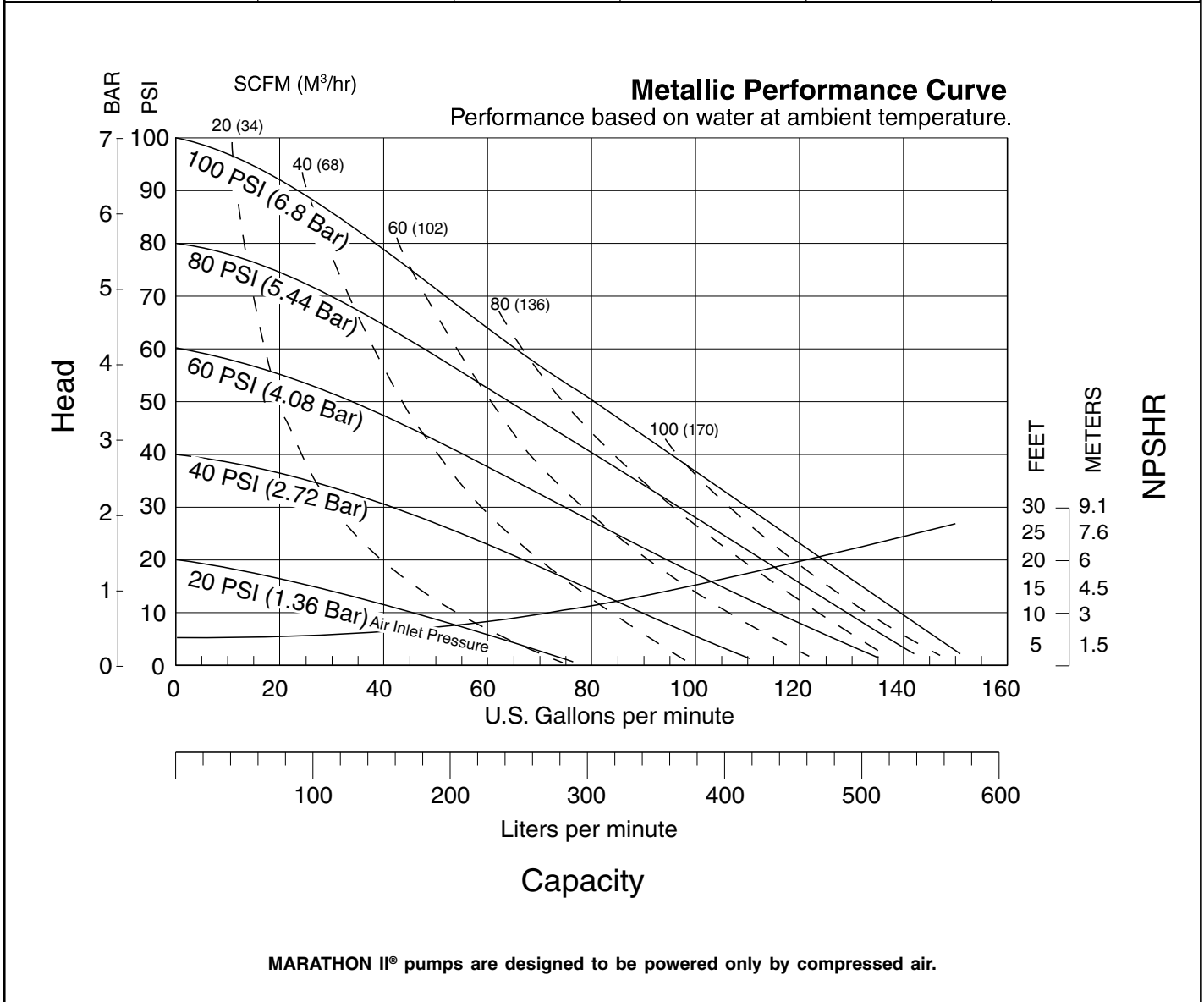

Explanation of Pump Nomenclature

M20 Metallic · Design Level 1· Ball Valve

MODEL	Pump Brand	Pump Size	Check Valve Type	Design Level	Wetted Material	Diaphragm/Check Valve Materials	Check Valve Seat	Non-Wetted Material Options	Porting Options	Pump Style	Pump Options	Shipping Kit Options	Weight lbs. (kg)
M20B1ABBANS000.	M	20	B	1	A	B	B	A	N	S	0	00.	53 (24)
M20B1AEEANS000.	M	20	B	1	A	E	E	A	N	S	0	00.	53 (24)
M20B1AGTANS000.	M	20	B	1	A	G	T	A	N	S	0	00.	53 (24)
M20B1ANNANS000.	M	20	B	1	A	N	N	A	N	S	0	00.	53 (24)
M20B1A1EANS000.	M	20	B	1	A	1	E	A	N	S	0	00.	53 (24)
M20B1AVTANS000.	M	20	B	1	A	V	T	A	N	S	0	00.	53 (24)
M20B1IBBANS000.	M	20	B	1	I	B	B	A	N	S	0	00.	93 (42)
M20B1IEEANS000.	M	20	B	1	I	E	E	A	N	S	0	00.	93 (42)
M20B1IGTANS000.	M	20	B	1	I	G	T	A	N	S	0	00.	93 (42)
M20B1INNANS000.	M	20	B	1	I	N	N	A	N	S	0	00.	93 (42)
M20B1I1EANS000.	M	20	B	1	I	1	E	A	N	S	0	00.	93 (42)
M20B1IVTANS000.	M	20	B	1	I	V	T	A	N	S	0	00.	93 (42)
M20B1IEEANS000.	M	20	B	1	I	E	E	A	N	S	0	00.	93 (42)
M20B1SBBANS000.	M	20	B	1	S	B	B	A	N	S	0	00.	95 (43)
M20B1SGTANS000.	M	20	B	1	S	G	T	A	N	S	0	00.	95 (43)
M20B1SNNANS000.	M	20	B	1	S	N	N	A	N	S	0	00.	95 (43)
M20B1S1EANS000.	M	20	B	1	S	1	E	A	N	S	0	00.	95 (43)
M20B1SVTANS000.	M	20	B	1	S	V	T	A	N	S	0	00.	95 (43)

Pump Brand

M= MARATHON II®

Pump Size

20= 2"

Check Valve Type

B= Ball

W= Weighted Ball

Design Level

1= Design Level

Wetted Material

A= Aluminum

I= Cast Iron

S= Stainless Steel

Diaphragm Check Valve Materials

1= Santoprene/Santoprene

B= Buna/Buna

C= Viton/PTFE

E= EPDM/EPDM

G= PTFE-Neoprene/PTFE

I= EPDM/ Santoprene

N= Neoprene/Neoprene

V= Viton/Viton

Check Valve Seat

A= Aluminum

B= Buna

C= Carbon Steel

E= EPDM

N= Neoprene

S= Stainless Steel

T= PTFE

V= Viton

Non-Wetted Material Options

A= Painted Aluminum

I= Cast Iron

J= Painted Aluminum

w/PTFE Coated Hardware

Y= Painted Aluminum

w/ Stainless Steel Hardware

Z= Cast Iron with Stainless Steel

Hardware

Porting Options

N= NPT Threads

B= BSPT (Tapered) Threads

Pump Style

S= Standard

Pump Options

0= None

2= Mesh Muffler

3= High temperature Air Valve

w/Encapsulated Muffler

4= High temperature Air Valve

w/Sound Dampening Muffler

5= High temperature Air Valve

w/Mesh Muffler

Kit Options

00.= None

P0.= 0-30VDC Pulse Output Kit

P1.= Intrinsically-Safe 10-30VDC

Pulse Output Kit

P2.= 110/120 or 220/240VAC

Pulse Output Kit

P3.= Intrinsically-Safe 110/120VAC

Pulse Output Kit

P4.= Intrinsically-Safe 220/240VAC

Pulse Output Kit

SP.= Stroke Indicator Pins

**CAUTION! Operating temperature limitations are as follows:**

Materials	Operating Temperatures		
	Maximum*	Minimum*	Optimum**
Buna General purpose, oil-resistant. Shows good solvent, oil, water and hydraulic fluid resistance. Should not be used with highly polar solvents like acetone and MEK, ozone, chlorinated hydrocarbons and nitro hydrocarbons.	190°F 88°C	-10°F -23°C	50° to 140°F 10°C to 60°C
EPDM Shows very good water and chemical resistance. Has poor resistance to oil and solvents, but is fair in ketones and alcohols.	212°F 100°C	-10°F -23°C	50° to 212°F 10°C to 100°C
Neoprene All purpose. Resistant to vegetable oil. Generally not affected by moderate chemicals, fats, greases and many oils and solvents. Generally attacked by strong oxidizing acids, ketones, esters, nitro hydrocarbons and chlorinated aromatic hydrocarbons.	170°F 77°C	-10°F -23°C	50° to 130°F 10°C to 54°C
Santoprene® Injection molded thermoplastic elastomer with no fabric layer. Long mechanical flex life. Excellent abrasion resistance.	212°F 100°C	-10°F -23°C	50° to 212°F 10°C to 100°C
Virgin PTFE Chemically inert, virtually impervious. Very few chemicals are known to react chemically with PTFE: molten alkali metals, turbulent liquid or gaseous fluorine and a few fluoro-chemicals such as chlorine trifluoride or oxygen difluoride which readily liberate free fluorine at elevated temperatures.	212°F 100°C	-35°F -37°C	50°F to 212°F 10°C to 100°C
Viton® Shows good resistance to a wide range of oils and solvents; especially all aliphatic, aromatic and halogenated hydrocarbons, acids, animal and vegetable oils. Hot water or hot aqueous solutions (over 70°F) will attack Viton®.	212°F 100°C	+32°F 0°C	75°F to 212°F 24°C to 100°C
Polyrthylene	150°F 65°C	40°F 5°C	

For specific applications, always consult "Chemical Resistance Chart" Technical Bulletin

*Definite reduction in service life.

**Minimal reduction in service life at ends of range.

©Santoprene is a registered tradename of Monsanto Corporation.

©Viton is a registered tradename of E.I. DuPont.

©Marathon and Warren Rupp are registered tradenames of Warren Rupp, Inc.

Dimensions: M20 Metallic

Dimensions in Inches

Dimensional Tolerance: $\pm 1/8"$

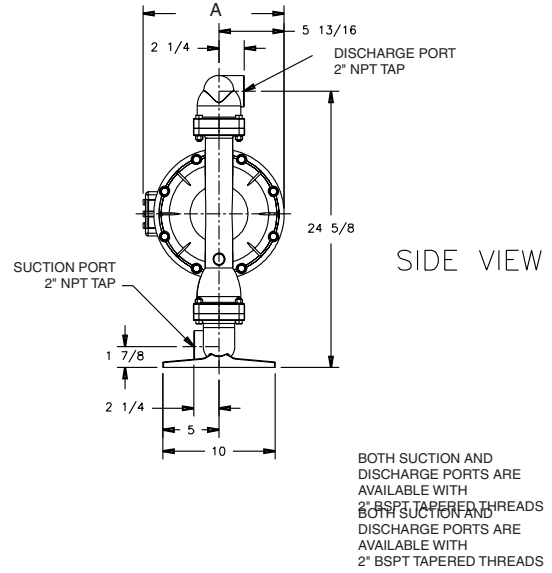
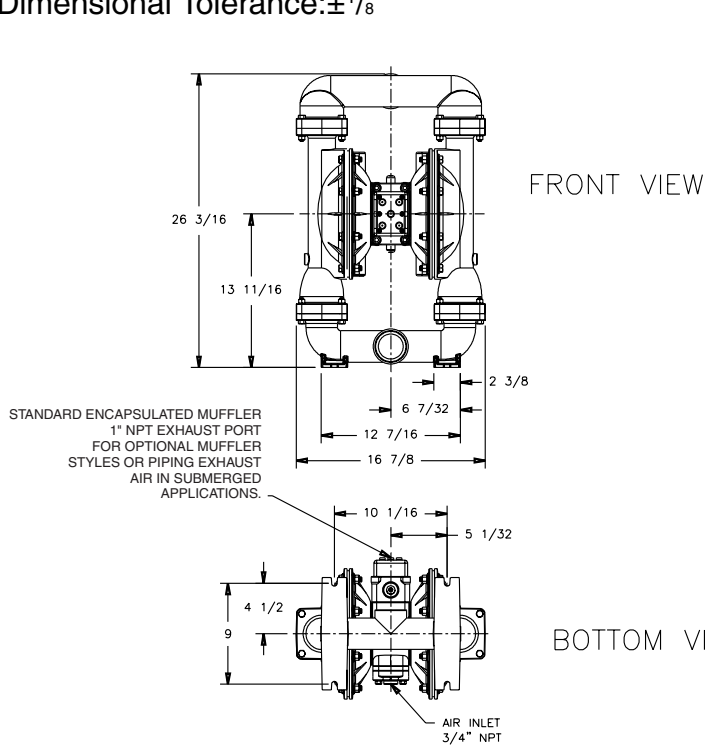

DIMENSION	A
Standard Pump	12 19/32
Pulse Output Kit	13 31/32
Mesh Muffler	14 17/32

Dimensions in Millimeters

Dimensional Tolerance: $\pm 3\text{mm}$

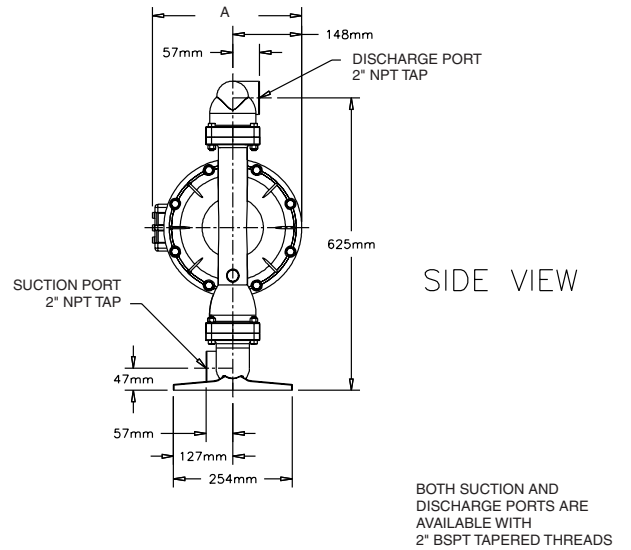
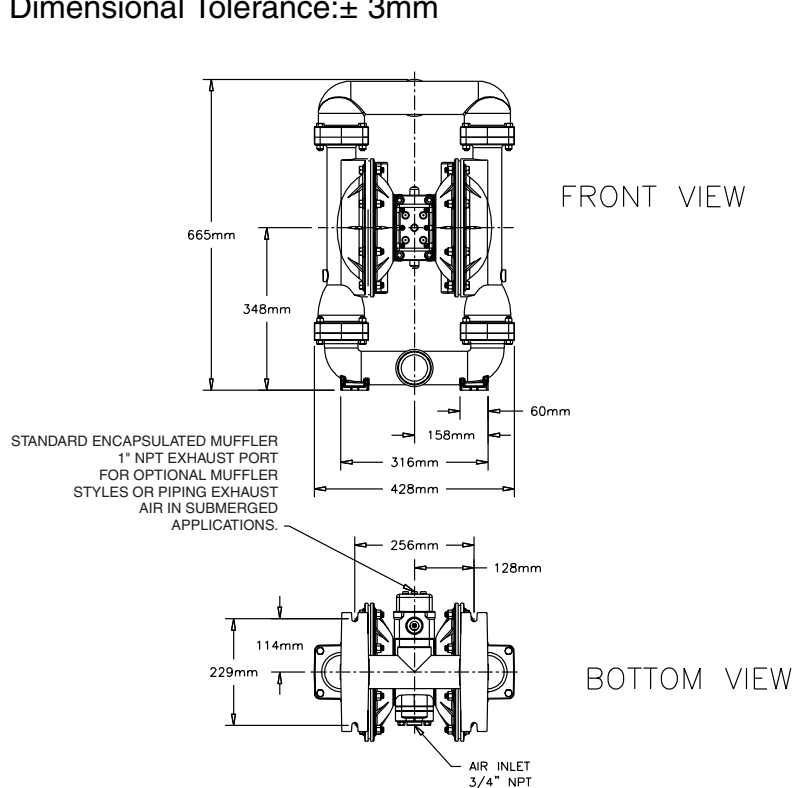

DIMENSION	A
Standard Pump	320
Pulse Output Kit	355
Mesh Muffler	369