

A2

Original™ Series **PLASTIC** Pumps

EOM

Engineering
Operation &
Maintenance



Simplify your process



ACCUFLO™
SOLENOID PUMP TECHNOLOGY

WILDEN®
A **DOVER** COMPANY

CE

WIL-10070-E-03
REPLACES WIL-10070-E-02

TABLE OF CONTENTS

	PAGE #
SECTION 1 - CAUTIONS - READ FIRST!	1
SECTION 2 - PUMP DESIGNATION SYSTEM	2
SECTION 3 - HOW IT WORKS (PUMP & AIR SYSTEMS)	3
SECTION 4 - DIMENSIONAL DRAWINGS	
A. A2T PLASTIC (T-series Center Section)	4
B. A2B PLASTIC (Adapter Block with T-series Center Section)	4
C. A2P PLASTIC (P-series Center Section).....	5
D. A2B PLASTIC (Adapter Block with P-series Center Section).....	5
SECTION 5 - PERFORMANCE CURVES	
A. A2T PLASTIC Rubber-Fitted (T-series Center Section).....	6
B. A2T PLASTIC PTFE-Fitted (T-series Center Section).....	6
C. A2P PLASTIC Rubber-Fitted (P-series Center Section).....	7
D. A2P PLASTIC PTFE-Fitted (P-series Center Section)	7
SECTION 6 - 70/30 OPERATING CONDITION	
A. A2T PLASTIC Rubber-Fitted (T-Series Center Section)	8
A. A2T PLASTIC PTFE-Fitted (T-Series Center Section)	8
B. A2P PLASTIC Rubber-Fitted (P-Series Center Section).....	8
B. A2P PLASTIC PTFE-Fitted (P-Series Center Section).....	8
SECTION 7 - INSTALLATION & OPERATION	
A. Installation	9
B. Operating Principles	10
C. Operation & Maintenance	10
D. Troubleshooting	11
SECTION 8 - DIRECTIONS FOR DISASSEMBLY/REASSEMBLY	
A. A2T, A2P & A2B Plastic Wetted Path	12-14
B. Reassembly Hints & Tips	15
SECTION 9 - EXPLODED VIEW/PARTS LISTING	
A. A2T PLASTIC (T-series Center Section)	16-17
B. A2P PLASTIC (P-series Center Section)	18-19
SECTION 10 - ELASTOMER OPTIONS/ELECTRICAL INFORMATION	
A. Elastomer Options	20
B. Electrical Information	20

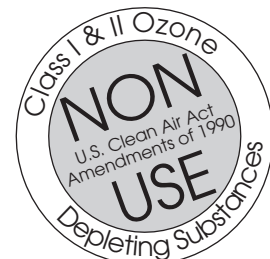

SECTION 1

A2 PLASTIC CAUTIONS – READ FIRST!



TEMPERATURE LIMITS:

Polypropylene	0°C to 79°C	32°F to 175°F
PVDF	-12°C to 107°C	10°F to 225°F
Neoprene	-17.8°C to 93.3°C	0°F to 200°F
Buna-N	-12.2°C to 82.2°C	10°F to 180°F
EPDM	-51.1°C to 137.8°C	-60°F to 280°F
Viton [®]	-40°C to 176.7°C	-40°F to 350°F
Wil-Flex [™]	-40°C to 107.2°C	-40°F to 225°F
Polyurethane	12.2°C to 65.6°C	10°F to 150°F
Saniflex [™]	-28.9°C to 104.4°C	-20°F to 220°F
PTFE	4.4°C to 104.4°C	40°F to 220°F



CAUTION: When choosing pump materials, be sure to check the temperature limits for all wetted components. Example: Viton has a maximum limit of 176.7°C (350°F) but polypropylene has a maximum limit of only 79°C (175°F).



CAUTION: Maximum temperature limits are based upon mechanical stress only. Certain chemicals will significantly reduce maximum safe operating temperatures. Consult engineering guide for chemical compatibility and temperature limits.



CAUTION: Always wear safety glasses when operating pump. If diaphragm rupture occurs, material being pumped may be forced out air exhaust.



WARNING: Prevention of static sparking — If static sparking occurs, fire or explosion could result. Pump, valves, and containers must be properly grounded when handling flammable fluids and whenever discharge of static electricity is a hazard.



CAUTION: Do not exceed 8.6 bar (125 psig) air supply pressure.



CAUTION: Plastic series pumps are made of virgin plastic and are not UV stabilized. Direct sunlight for prolonged periods can cause deterioration of plastics.



CAUTION: Before any maintenance or repair is attempted, the compressed air line to the pump should be disconnected and all air pressure allowed to bleed from pump. Disconnect all intake, discharge and air lines. Drain the pump by turning it upside down and allowing any fluid to flow into a suitable container.



CAUTION: Blow out air line for 10 to 20 seconds before attaching to pump to make sure all pipe line debris is clear. Use an in-line air filter. A 5 μ (micron) air filter is recommended.



NOTE: Tighten clamp bands and retainers prior to installation. Fittings may loosen during transportation.



NOTE: When installing PTFE diaphragms, it is important to tighten outer pistons simultaneously (turning in opposite directions) to ensure tight fit.



NOTE: Before starting disassembly, mark a line from each liquid chamber to its corresponding air chamber. This line will assist in proper alignment during reassembly.



CAUTION: Verify the chemical compatibility of the process and cleaning fluid to the pump's component materials in the Chemical Resistance Guide (see RBG E4).



CAUTION: Only explosion proof (NEMA 7) solenoid valves should be used in areas where explosion proof equipment is required.



CAUTION: Do not lubricate lube-free pumps.



CAUTION: The A2 pump is not submersible.



NOTE: When reinstalling the outer pistons, apply two (2) drops of Loctite[®] 246 to the shaft internal threads before the diaphragm assembly.

SECTION 2

WILDEN PUMP DESIGNATION SYSTEM

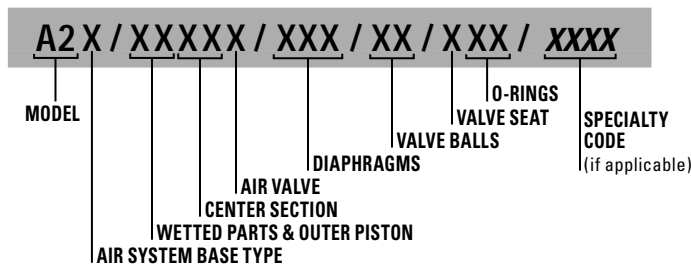

MODEL A2 PLASTIC MATERIAL CODES

AIR SYSTEM BASE TYPE

B = ADAPTER BLOCK
 P = PRO-FLO®
 T = TURBO-FLO™

WETTED PARTS & OUTER PISTON

KK = PVDF / PVDF
 PP = POLYPROPYLENE /
 POLYPROPYLENE

CENTER SECTION

PP = POLYPROPYLENE

AIR VALVE

A = ALUMINUM (available on A2T
 only)
 P = POLYPROPYLENE
 U = UHMW PE (available
 on A2B only)

DIAPHRAGMS

BNS = BUNA-N (Red Dot)
 EPS = EPDM (Blue Dot)
 FSS = SANIFLEX™
 (Hytre® (Cream))
 NES = NEOPRENE (Green Dot)
 PUS = POLYURETHANE (Clear)
 TEU = PTFE W/EPDM
 BACK-UP (White)
 TNU = PTFE W/NEOPRENE
 BACK-UP (White)
 TSU = PTFE W/SANIFLEX™ BACK-UP
 (White)
 VTS = VITON® (White Dot)
 WFS = WIL-FLEX™ (Santoprene®
 (Orange Dot))

VALVE BALL

BN = BUNA-N (Red Dot)
 EP = EPDM (Blue Dot)
 FS = SANIFLEX™
 (Hytre® (Cream))
 NE = NEOPRENE (Green Dot)
 PU = POLYURETHANE (Brown)
 TF = PTFE (White)
 VT = VITON® (White Dot)
 WF = WIL-FLEX™ (Santoprene®
 (Orange Dot))

VALVE SEAT

K = PVDF
 P = POLYPROPYLENE

VALVE SEAT O-RING

BN = BUNA-N
 PU = POLYURETHANE (Brown)
 TV = PTFE ENCAP. VITON®
 WF = WIL-FLEX™ (Santoprene®)

SPECIALTY CODES

0261 A2 Plastic, Accu-Flo™, 24V AC / 12V DC coil
 0262 A2 Plastic, Accu-Flo™, 24V AC / 12V DC x-proof coil
 0263 A2 Plastic, Accu-Flo™, 24V DC coil
 0264 A2 Plastic, Accu-Flo™, 24V DC x-proof coil
 0265 A2 Plastic, Accu-Flo™, 110V AC coil
 0266 A2 Plastic, Accu-Flo™, 110V AC x-proof coil
 0271 A2 Plastic, Accu-Flo™, 110V AC coil, Wil-Gard II™ 110V
 0272 A2 Plastic, Accu-Flo™, 24V AC / 12V DC coil,
 SS outer pistons
 0273 A2 Plastic, Accu-Flo™, 24V DC coil, Wil-Gard II™ 110V
 0362 Accu-Flo™, 110V AC coil, PFA coated hardware,
 Wil-Gard II™ 110V
 0451 A2 Plastic, Accu-Flo™, no coil, DIN flange

0454 A2 Plastic, Accu-Flo™, 24V DC coil, DIN flange
 0455 A2 Plastic, Accu-Flo™, 24V AC / 12V DC coil, DIN flange
 0456 A2 Plastic, Accu-Flo™, 24V DC,
 Intl. x-proof coil, DIN flange
 0457 A2 Plastic, Accu-Flo™, 24V DC coil,
 SS outer pistons, DIN flange
 0458 A2 Plastic, Accu-Flo™, 24V DC coil,
 Wil-Gard II™ 220V, DIN flange
 0567 Split manifold, Accu-Flo™, 24V DC coil
 0570 Split manifold, Accu-Flo™, 24V AC / 12V DC coil
 0509 adapter block, no muffler, P2R center section
 0518 adapter block, no muffler, T2R center section

NOTE: MOST ELASTOMERIC MATERIALS USE COLORED DOTS FOR IDENTIFICATION.

THE THREE ACCU-FLO™ OPTIONS AVAILABLE:

1. AxT: This is the same Accu-Flo™ configuration that has been available from Wilden since March 1994. An aluminum solenoid valve is attached directly to a T-series center section and the shaft/inner piston configuration is altered.
 2. AxP: This option uses a plastic (polypropylene or acetal) spacer that is assembled between the Pro-Flo® air valve and the Pro-Flo® center section. The same solenoid operator – coil assembly that is found on AxT pumps is assembled on the plastic spacer discussed above for electronic interface. This spacer combined with the Pro-Flo® air valve replaces the aluminum air valve used in the AxT with a more chemically resistant option. Spacers will be available in the 1/4",

1/2", and 1" sizes. The use of the Pro-Flo® ADS provides additional flow in most applications (refer to EOM for details). The AxP provides the Pro-Flo® benefits of lower start-up pressure, reduced blow-by, and increased life.
 3. AxB: This option uses an Adapter Block in place of an air valve. A user supplied, 4-way pneumatic valve must be used in conjunction with this technology. This configuration enables the solenoid valve to be remotely installed, preventing chemical attack in very aggressive environments. Adapter Blocks are available for both the T and P-series center sections in all pump sizes. (See EOM AxB for details.) Note: the "x" in the above Accu-Flo™ descriptions are used in place of a pump model size. See Pump Designation System chart above.

Viton is a registered trademark of DuPont Dow Elastomers.

SECTION 3

THE WILDEN PUMP — HOW IT WORKS

The Wilden diaphragm pump is an air-operated, positive displacement, self-priming pump. These drawings show the flow pattern through the pump upon its initial stroke. It is assumed the pump has no fluid in it prior to its initial stroke.

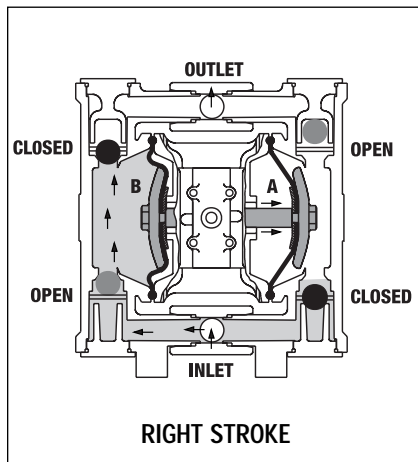

FIGURE 1 When the solenoid is energized, the air valve directs pressure to the back side of diaphragm A. The compressed air is applied directly to the liquid column separated by elastomeric diaphragms. The diaphragm acts as a membrane between the compressed air and the liquid, balancing the load and removing mechanical stress from the diaphragm. The compressed air moves the diaphragm away from the center section of the pump. The opposite diaphragm is pulled in by the shaft connected to the pressurized diaphragm. Diaphragm B is on its suction stroke; air behind the diaphragm has been forced out to the atmosphere through the exhaust port. The movement of diaphragm B toward the center section of the pump creates a vacuum within chamber B. Atmospheric pressure forces fluid into the inlet manifold forcing the inlet valve ball off of its seat. Liquid is free to move past the inlet valve ball and fill the liquid chamber (see shaded area).

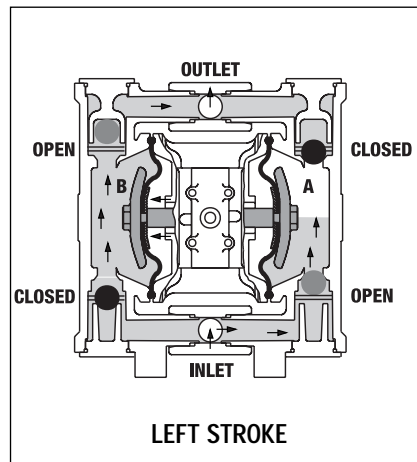

FIGURE 2 When the solenoid valve is deenergized, the air valve redirects pressurized air to the back side of diaphragm B. The pressurized air forces diaphragm B away from the center section while pulling diaphragm A to the center section. Diaphragm B is now on its discharge stroke. Diaphragm B forces the inlet valve ball onto its seat due to the hydraulic forces developed in the liquid chamber and manifold of the pump. These same hydraulic forces lift the discharge valve ball off of its seat, while the opposite discharge valve ball is forced onto its seat, forcing fluid to flow through the pump discharge. The movement of diaphragm A toward the center section of the pump creates a vacuum within liquid chamber A. Atmospheric pressure forces fluid into the inlet manifold of the pump. The inlet valve ball is forced off of its seat allowing the fluid being pumped to fill the liquid chamber.

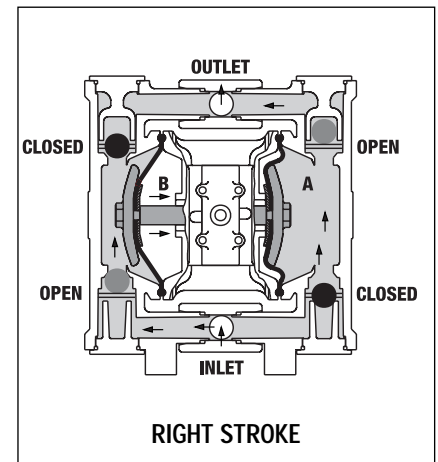
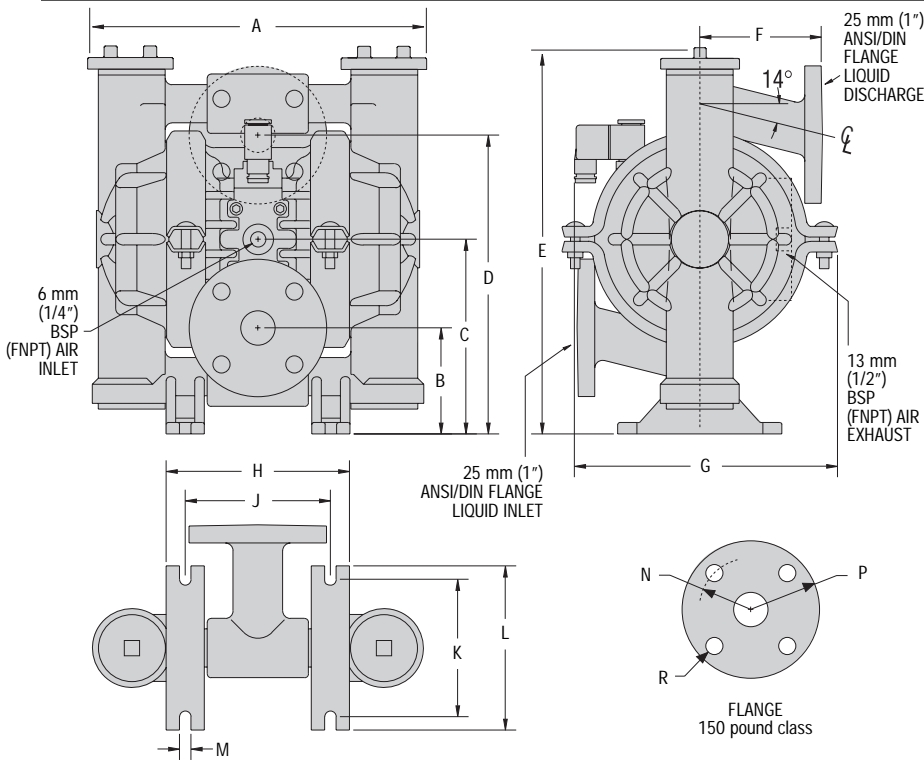

FIGURE 3 Once the solenoid valve is reenergized, the air is directed to the back side of diaphragm A, which starts diaphragm B on its exhaust stroke. As the pump reaches its original starting point, each diaphragm has gone through one intake and one discharge stroke. This constitutes one complete pumping cycle. The pump may take several cycles to completely prime depending on the conditions of the application.

SECTION 4A

DIMENSIONAL DRAWING A2T PLASTIC ACCU-FLO™



DIMENSIONS

ITEM	METRIC (mm)	STANDARD (inch)
A	297	11.7
B	74	2.9
C	163	6.4
D	251	9.9
E	335	13.2
F	107	4.2
G	229	9.0
H	157	6.2
J	124	4.9
K	114	4.5
L	137	5.4
M	10	0.4
N	79 DIA.	3.1 DIA.
P	109 DIA.	4.3 DIA.
R	15 DIA.	0.6 DIA.

SECTION 4B

DIMENSIONAL DRAWING A2B PLASTIC (T-SERIES CENTER SECTION)

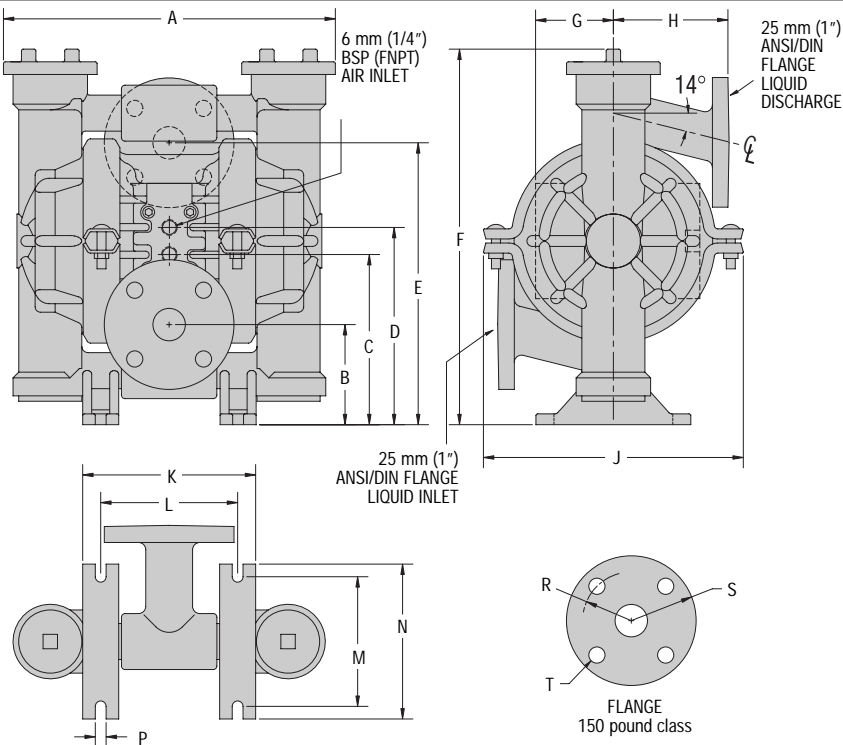

DIMENSIONS

ITEM	METRIC (mm)	STANDARD (inch)
A	297	11.7
B	74	2.9
C	150	5.9
D	173	6.8
E	251	9.9
F	335	13.2
G	69	2.7
H	107	4.2
J	239	9.4
K	114	4.5
L	137	5.4
M	124	4.9
N	157	6.2
P	10	0.4
R	79 DIA.	3.1 DIA.
S	109 DIA.	4.3 DIA.
T	15 DIA.	0.6 DIA.

SECTION 4C

DIMENSIONAL DRAWING A2P PLASTIC ACCU-FLO™

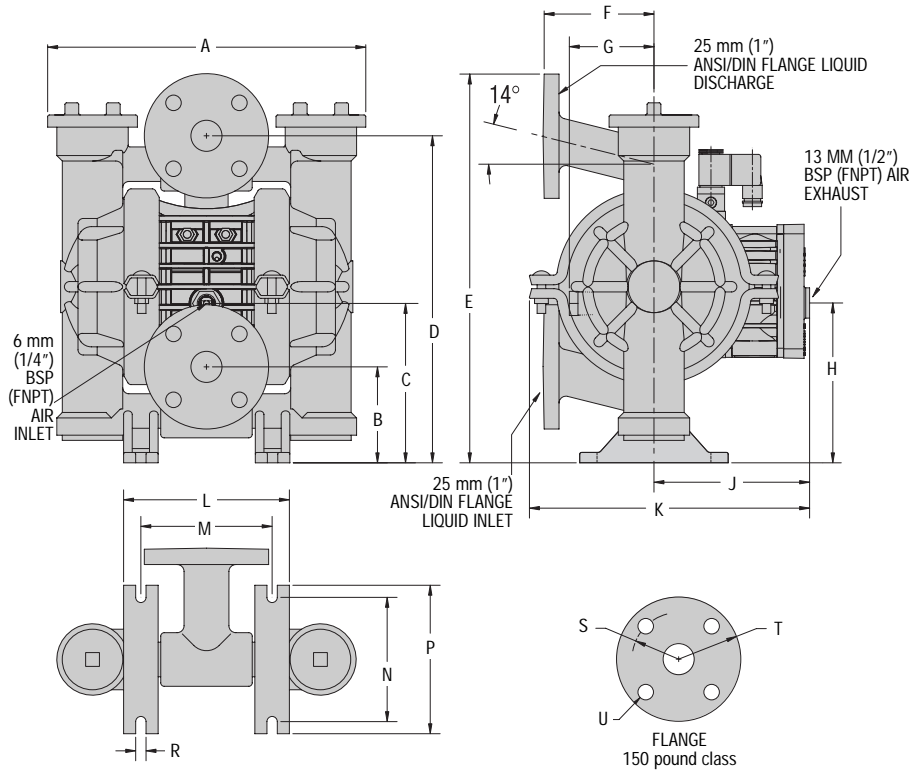

DIMENSIONS

ITEM	METRIC (mm)	STANDARD (inch)
A	297	11.7
B	74	2.9
C	147	5.8
D	307	12.1
E	356	14.0
F	107	4.2
G	69	2.7
h	91	3.6
J	142	5.6
K	259	10.2
L	114	4.5
M	137	5.4
N	124	4.9
P	157	6.2
R	10	0.4
S	79 DIA.	3.1 DIA.
T	109 DIA.	4.3 DIA.
U	15 DIA.	0.6 DIA.

SECTION 4D

DIMENSIONAL DRAWING A2B PLASTIC (P-SERIES CENTER SECTION)

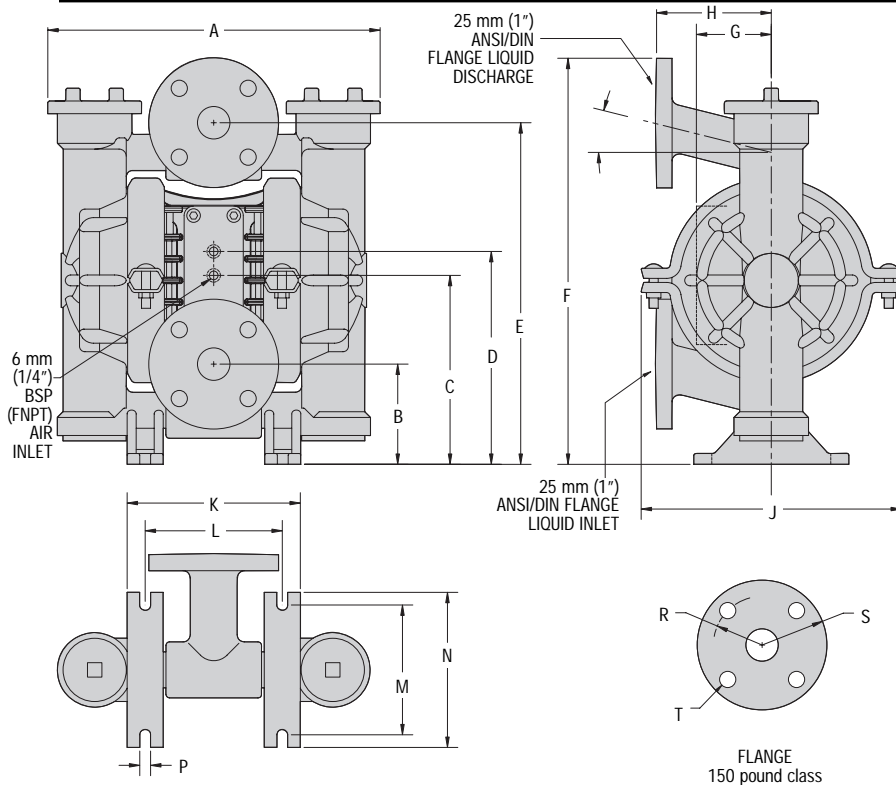

DIMENSIONS

ITEM	METRIC (mm)	STANDARD (inch)
A	297	11.7
B	74	2.9
C	168	6.6
D	188	7.4
E	307	12.1
F	356	14.0
G	66	2.6
H	107	4.2
J	239	9.4
K	114	4.5
L	137	5.4
M	124	4.9
N	157	6.2
P	10	0.4
R	79 DIA.	3.1 DIA.
S	109 DIA.	4.3 DIA.
T	15 DIA.	0.6 DIA.

SECTION 6A

70/30 OPERATING CONDITION A2T PLASTIC PLASTIC ACCU-FLO™

These curves demonstrate the flow created when the stroke rate is modified under static air and fluid pressure condition. This curve can be applied to different pressure conditions to estimate the change in flow due to stroke rate.

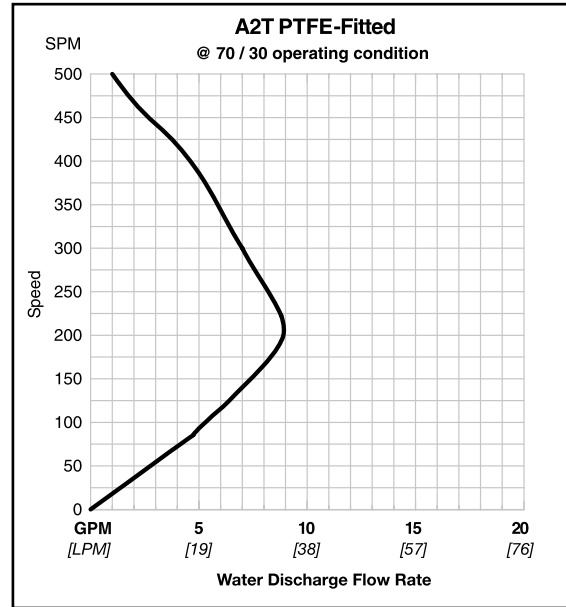
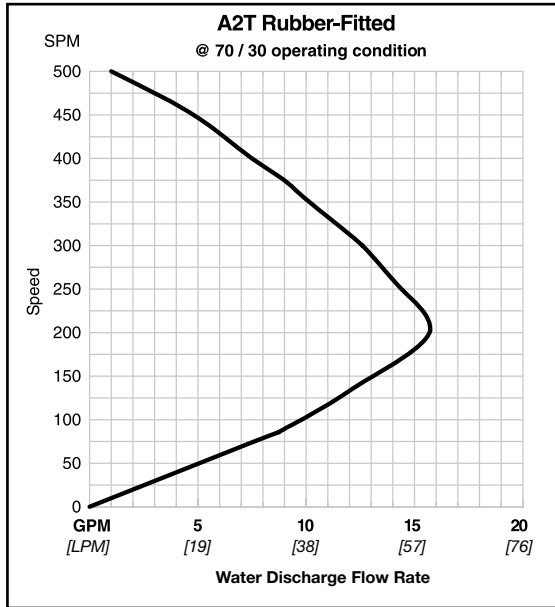

SECTION 6B

70/30 OPERATING CONDITION A2P PLASTIC PLASTIC ACCU-FLO™

These curves demonstrate the flow created when the stroke rate is modified under static air and fluid pressure condition. This curve can be applied to different pressure conditions to estimate the change in flow due to stroke rate.

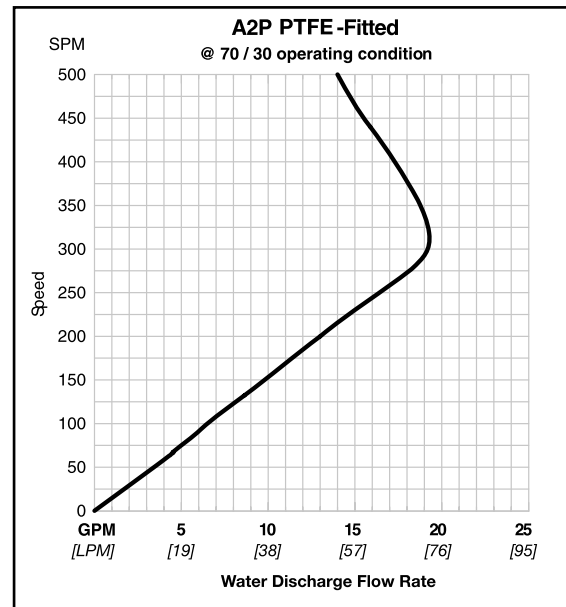
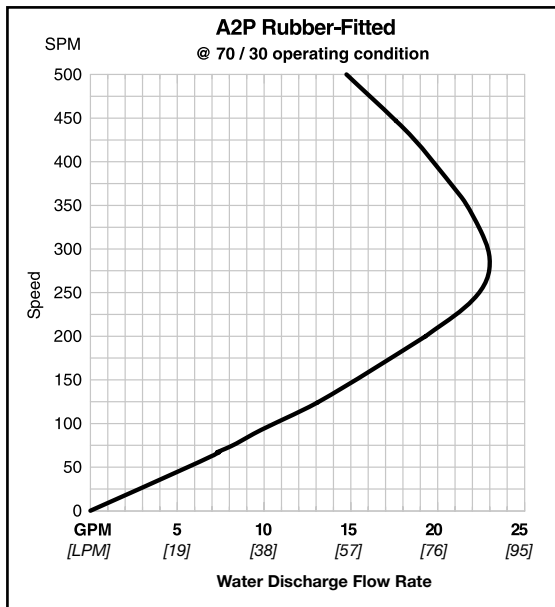

SECTION 7A

INSTALLATION

All Wilden pumps are manufactured with a variety of materials for the air distribution system, liquid path and elastomers. This variety is offered to satisfy the temperature, chemical compatibility, abrasion and flex life requirements for most applications. Consult manual for available materials and temperature limitations for this pump model.

For Accu-Flo™ models only, all wiring used to operate the pump should be placed and connected according to all applicable electrical codes. It is important that the wiring be of adequate gauge to carry the current required to operate the pump. In addition, it is necessary that the electrical power supply be large enough to supply the current required to operate the pump. Wiring should be above ground level if possible (in case of fluid spill or leakage), and all wiring and connections which could become wet or damp should be made watertight.

The suction pipe used for installation should be sized equal to, or greater than, the pump liquid inlet connection. This will minimize pump cavitation and potential blockages of the pump inlet. The discharge piping should also be sized equal to, or greater than, the pump liquid discharge connection. If the pump is to be used in a self-priming application, be sure that all connections are airtight and that the suction lift is within the pump's ability. (Consult manual for suction lift information.) Note: Materials of construction and elastomer materials have an effect on suction lift parameters.

INSTALLATION: Months of careful planning, study and selection efforts can result in unsatisfactory pump performance if installation details are left to chance.

Premature failure and long term dissatisfaction can be avoided if reasonable care is exercised throughout the installation process.

LOCATION: Noise, safety, and other logistical factors usually dictate that "utility" equipment be situated away from the production floor. Multiple installations with conflicting requirements can result in congested utility areas, leaving few choices for siting additional pumps.

Within the framework of these and other existing conditions, every pump should be located in such a way that four key factors are balanced against each other to maximum advantage.

1. **ACCESS:** First of all, the location should be accessible. If it is easy to reach the pump, maintenance personnel will have an easier time carrying out routine inspections and adjustments. Should major repairs become necessary, ease of access can play a key role in speeding the repair process and reducing total downtime.

2. **AIR SUPPLY:** Every pump location should have an air line large enough to supply the volume of air necessary to achieve the desired pumping rate. (Consult manual for performance information.) The use of an air filter before the pump will ensure that the majority of pipeline contaminants will be

eliminated. For best results, the pump should use an air filter, regulator system.

Sound levels are reduced below OSHA specifications using the standard Wilden muffler.

3. **ELEVATION:** Selecting a site that is well within the pump's dynamic lift capability will assure that a loss-of-prime condition will be avoided. In addition, pump efficiency can be adversely effected if proper attention is not given to site location.

4. **PIPING:** Final determination of the pump site should not be made until the piping problems of each possible location have been evaluated. The impact of current and future installations should be considered ahead of time to make sure that inadvertent restrictions are not created for any remaining sites.

The best choice possible will be a site involving the shortest and straightest hook-up of suction and discharge piping. Unnecessary elbows, bends, and fittings should be avoided. Pipe sizes should be selected so as to keep friction losses within practical limits. All piping should be supported independently of the pump to avoid damage. In addition, the piping should be aligned so as to avoid placing stress on the pump fittings.

Flexible hose can be installed to aid in absorbing the forces created by the natural reciprocating action of the pump. If the pump is to be bolted down to a solid location, a mounting pad placed between the pump and the foundation will assist in minimizing pump vibration. Flexible connections between the pump and rigid piping will also assist in minimizing pump vibration. If quick-closing valves are installed at any point in the discharge system, or if pulsation within a system becomes a problem, a Wilden Equalizer surge dampener should be installed to protect the pump, piping and gauges from surges and water hammer. Installation of a tee at the discharge of the pump will allow the addition of an Equalizer to the system at a later date without requiring piping modifications. Installation of inlet and discharge isolation valves are also recommended to make service and repair easier.

Pumps in service with a positive suction head are most efficient when pressure is limited to 0.4 - 0.7 bar (7-10 psig). Premature diaphragm failure may occur if positive suction exceeds these recommended pressures.

A STRAINER SHOULD BE USED ON THE SUCTION LINE OF THE SYSTEM IF THERE IS A POSSIBILITY THAT SOLIDS ENTERING THE PUMP MAY EXCEED THE PUMP'S SOLIDS HANDLING CAPABILITIES.

PLEASE READ AND FOLLOW ALL CAUTIONS NOTED IN THIS MANUAL.

Pump should be thoroughly flushed before installing into process line.

Blow out air line for 10 to 20 seconds before attaching pump to clear all pipe line debris.

SECTION 7B - OPERATING PRINCIPLES

When the solenoid is unpowered, one air chamber is pressurized with air, while the opposite chamber is exhausted. When electric power is applied, the solenoid shifts, and the pressurized air chamber is exhausted while the opposite chamber is pressurized. By alternately applying and removing power, the solenoid-operated pump runs like a standard Wilden pump.

The speed of the pump is controlled electrically. Since each stroke is controlled by an electrical signal, the pump is ideal for batching and other electrically controlled dispensing applications.

Although the speed of the pump is controlled electrically, the air pressure is important. Air pressure displaces the fluid, and if the pressure is insufficient to complete the physical stroke before an electronic impulse signals the pump to shift, the stroke will not be completed, and the displacement per stroke will be reduced. This does not harm the unit in any way, but it may cause inaccuracy when attempting to batch specific quantities with high precision if this effect is not taken into account.

There are three coil voltage options available. One coil allows for 24V DC operation. The second coil option allows for operation with either 12V DC or 24V AC at 60 Hz and the third coil option allows for 110V AC operation.

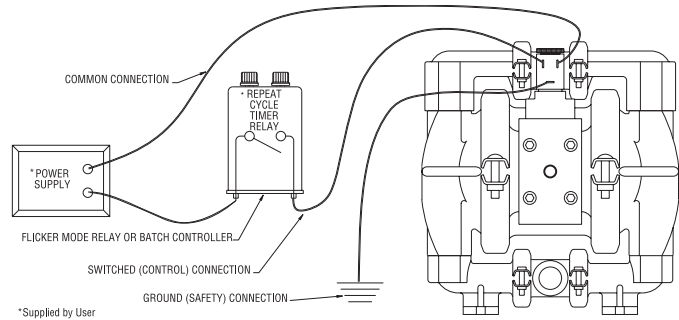

ACCU-FLO™ PLUMBING CONNECTIONS

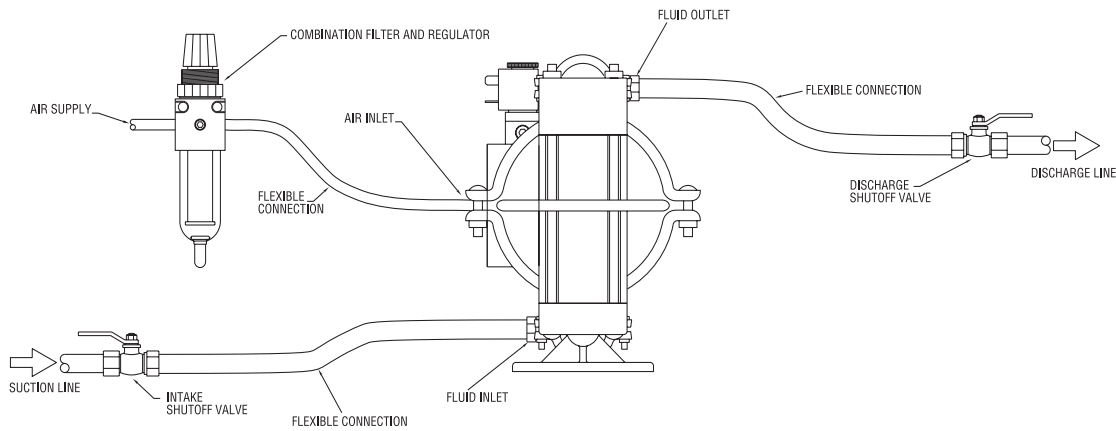

SECTION 7C - ACCU-FLO™

SUGGESTED OPERATION AND MAINTENANCE INSTRUCTIONS

OPERATION: The speed of the pump is controlled electrically. Since each stroke is controlled by an electrical signal, the pump is ideal for batching and other electrically controlled dispensing applications.

The pump will not shift reliably unless the minimum supply pressure is supplied. For the A2T the minimum supply pressure for reliable operation is 2.7 bar (40 psig).

The solenoid operated pump is permanently lubricated during assembly, and requires no additional lubrication under normal operation. If the unit runs under extreme conditions (continuous operation at high speeds), it may be necessary to relubricate the center block with a **Buna-N compatible NLGI Grade 2 grease** every 50 million cycles. Continuous lubrication with a compatible oil is not harmful, and will provide longer seal life, but it may flush all grease out of the unit.

A red button on the side of the air valve is a manual override; when actuated it will shift the valve as if an electric current had actuated the solenoid.

RECORDS: When service is required, a record should be made of all necessary repairs and replacements. Over a period of time, such records can become a valuable tool for predicting and preventing future maintenance problems and unscheduled downtime. In addition, accurate records make it possible to identify pumps that are poorly suited to their applications.

MAINTENANCE AND INSPECTIONS: Since each application is unique, maintenance schedules may be different for every pump. Frequency of use, line pressure, viscosity and abrasiveness of process fluid all effect the parts life of a Wilden pump. Periodic inspections have been found to offer the best means for preventing unscheduled pump downtime. Personnel familiar with the pump's construction and service should be informed of any abnormalities that are detected during operation. Internal maintenance is not recommended for Accu-Flo™ solenoid air valves. When worn or damaged, a new air valve body, coil or terminal connector must be purchased. Please consult section 9 for part numbers.

TROUBLESHOOTING

Pump will not run.

1. Check for pressurized air at the inlet.
2. Check air inlet and filter for debris.
3. Connect a test lamp to the two wires which run to pump and ensure that the lamp cycles on and off.
4. Make sure that the air valve manual override (small red knob on front of valve) is switched to the "0" position.
5. Check pilot pressure vent at the top of the operator/coil assembly to ensure that it is not clogged.
6. Check for a worn out air valve. If air continually blows out the exhaust in very large quantities, the air valve seals may be worn beyond their ability to function. In this case, the valve must be replaced.

NOTE: Before the valve is scrapped, it is possible that it may be saved by completely disassembling the valve, cleaning all components and relubricating the valve.

Pump runs but little or no fluid comes out.

1. Check that the discharge isolation valve is not closed.
2. Check that the electronic signal is slow enough that the pump is able to complete each physical stroke before it is signaled to change direction. The time required to complete the stroke is determined by a variety of factors which include fluid viscosity and head pressure.
3. Check for pump cavitation; slow pump speed down to match the thickness of the material being pumped.
4. Check for sticking ball check valves. If the material being pumped is not compatible with the pump elastomers, swelling may occur. Replace ball check valves and o-ring with the proper elastomers.
5. Check to make sure that all suction connections are air tight, and that the clamp bands are properly tightened.

Pump air passages blocked with ice.

1. Check for excessive moisture in compressed air line. As the air expands out the exhaust during the operation of the pump, water vapor entrapped in the compressed air

can freeze and block the air passageways in the pump. If this occurs, it may be necessary to install a coalescing filter, an air dryer, or a hot air generator for the compressed air.

Air bubbles in pump discharge.

1. Check for ruptured diaphragm.
2. Check tightness of clamp bands, and the integrity of the o-rings, especially at intake manifold.

Product comes out air exhaust.

1. Check for diaphragm rupture.
2. Check tightness of piston plates to shaft.

Pump rattles.

1. See E9 Troubleshooting Guide.
2. Create false discharge head or suction lift.

Solenoid buzzes or solenoid burnout.

1. Incorrect voltage, faulty or dirty solenoid.

Solenoid valve fails to shift electrically but shifts with manual override.

1. Incorrect voltage, defective coil or wiring.

Solenoid valve fails to shift electrically or with manual override.

1. Inadequate air supply, contamination, inadequate or improper lubrication, mechanical binding in the valve.

Valve shifts but fails to return.

1. Broken spring, mechanical binding.

Excessive leaking from air valve vent.

1. Worn seals in air valve.

SECTION 8A

A2 PLASTIC

DIRECTIONS FOR DISASSEMBLY/REASSEMBLY

CAUTION: Before any maintenance or repair is attempted, the compressed air line to the pump should be disconnected and all air pressure allowed to bleed from the pump. Disconnect all intake, discharge, and air lines. Drain the pump by turning it upside down and allowing any fluid to flow into a suitable container. Be aware of any hazardous effects of contact with your process fluid.

The Wilden model A2 has a 25 mm (1") inlet and 25 mm (1") outlet and is designed for flows up to 136 lpm (36 gpm). The wetted path comes in both PVDF and polypropylene. The single-piece center section, consisting of center block and air chambers, is molded of polypropylene. All o-rings used in the pump are of a special material and shore hardness that should only be replaced with factory-supplied parts.

TOOLS REQUIRED:

1/2" Box Wrench
1/2" Socket
3/16" Allen Wrench
1/2" Socket Drive
2 - 1" Sockets or Adjustable Wrench
Adjustable Wrench
Vise equipped with soft jaws (such as plywood, plastic or other suitable material)

NOTE: The model used for these instructions incorporates PTFE diaphragms, balls, and seats. Models with rubber diaphragms, balls and seats are the same except where noted.



DISASSEMBLY:

Figure 1

Step 1.

Before starting disassembly, mark a line from each liquid chamber to its corresponding air chamber. This line will assist in proper alignment during reassembly.

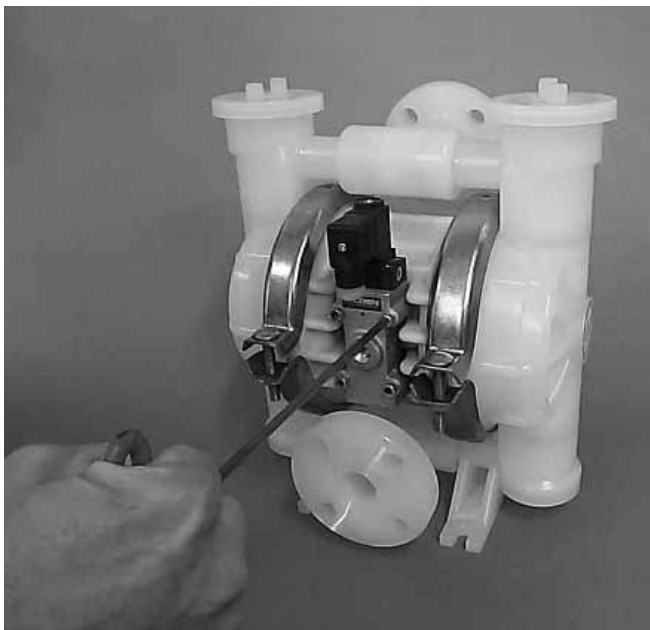

Step 2.

Figure 2

Using the 3/16" Allen Wrench, remove air valve bolts. Inspect air valve assembly for wear or damage.



Step 3.

Figure 3

Using a screwdriver or other long, slim object, loosen the top liquid retainers from the liquid chambers.



Step 4. *Figure 4*

Remove the top liquid retainer to expose the valve balls, valve seats and valve seat o-rings.



Step 5. *Figure 5*

Remove the top liquid retainer and retainer o-rings, discharge valve balls, seats and valve seat o-rings from the liquid chamber and inspect for nicks, gouges, chemical attack or abrasive wear. Replace worn parts with genuine Wilden parts for reliable performance.



Step 6. *Figure 6*

Using a 1/2" socket driver, loosen the bottom retainers.



Step 7. *Figure 7*

Remove the bottom liquid retainer and retainer o-rings, discharge valve balls, seats and valve seat o-rings from the liquid chamber and inspect for nicks, gouges, chemical attack or abrasive wear. Replace worn parts with genuine Wilden parts for reliable performance.

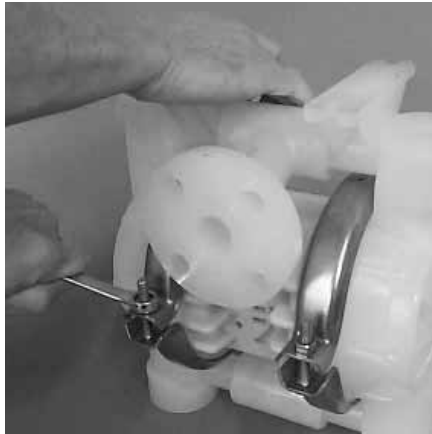

Step 8. *Figure 8*

With a 1/2" box wrench, loosen the large clamp bands that secure the liquid chambers to the center section.



Step 9. *Figure 9*

Rotate the clamp bands so that they can be removed.

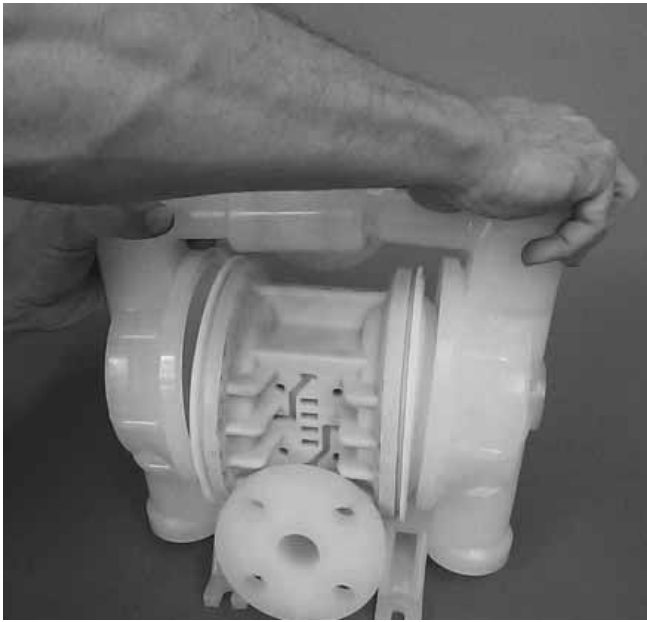

Step 10. *Figure 10*
After clamp bands are removed, pull liquid chambers apart.

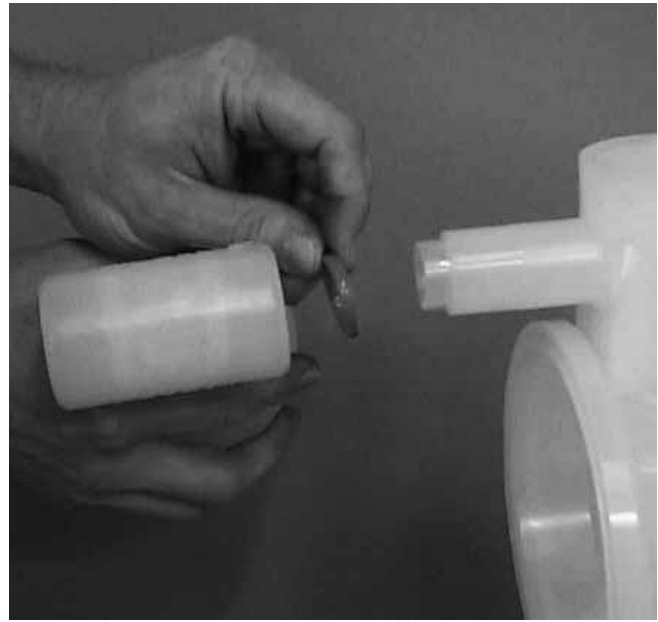

Step 11. *Figure 11*
Remove tee section from liquid chamber and inspect o-rings for signs of wear. Replace worn parts with genuine Wilden parts for reliable performance.

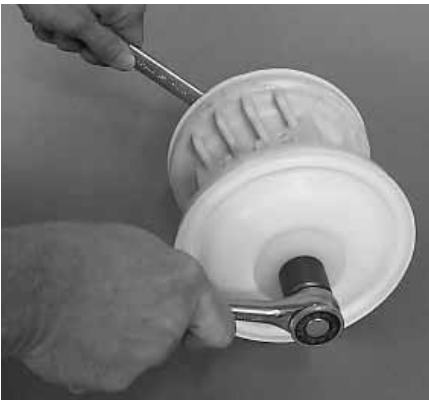

Step 12. *Figure 12*
Using two 1" sockets, remove diaphragm assembly from center section assembly.



Step 13. *Figure 13*
To remove the remaining diaphragm assembly from the shaft, secure shaft with soft jaws (a vise fitted with plywood or other suitable material) to ensure shaft is not nicked, scratched, or gouged. Using hands or an adjustable wrench, remove diaphragm assembly from shaft. Inspect all parts for wear and replace with genuine Wilden parts if necessary.

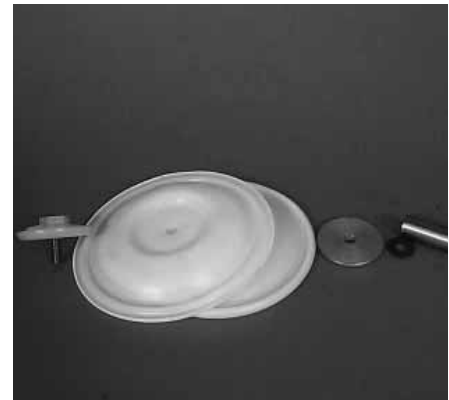

Step 14. *Figure 14*
Inspect diaphragms, outer and inner pistons and disc spring (not shown) for signs of wear. Replace with genuine Wilden parts if necessary.

SECTION 8B

REASSEMBLY HINTS & TIPS

ASSEMBLY:

Upon performing applicable maintenance to the air distribution system, the pump can now be reassembled. Please refer to the disassembly instructions for photos and parts placement. To reassemble the pump, follow the disassembly instructions in reverse order. The air distribution system needs to be assembled first, then the diaphragms and finally the wetted path. Please find the applicable torque specifications on this page. The following tips will assist in the assembly process.

- Clean the inside of the center section shaft bushing to ensure no damage is done to new seals.
- Stainless bolts should be lubed to reduce the possibility of seizing during tightening.
- Be sure to tighten outer pistons simultaneously on PTFE-fitted pumps to ensure proper torque values.
- Apply two (2) drops of Loctite® 246 to the shaft internal threads before the diaphragm assembly.

MAXIMUM TORQUE SPECIFICATIONS

Description of Part	Plastic Pumps
Solenoid Air Valve (Turbo-Flo™)	2.3 N•m (20 in-lbs)
Solenoid Air Valve (Pro-Flo®)	3.1 N•m (27 in-lbs)
Adapter Block Air Valve	3.1 N•m (27 in-lbs)
Outer Piston — Rubber- and PTFE-fitted	27.1 N•m (20 ft-lbs)
Top and Bottom Retainers	14.1 N•m (125 in-lbs)
Large Clamp Band — Rubber-fitted	10.7 N•m (95 in-lbs)
Large Clamp Band — PTFE-fitted	14.1 N•m (125 in-lbs)

SECTION 9A

EXPLODED VIEW/PARTS LISTING

A2T PLASTIC ACCU-FLO™

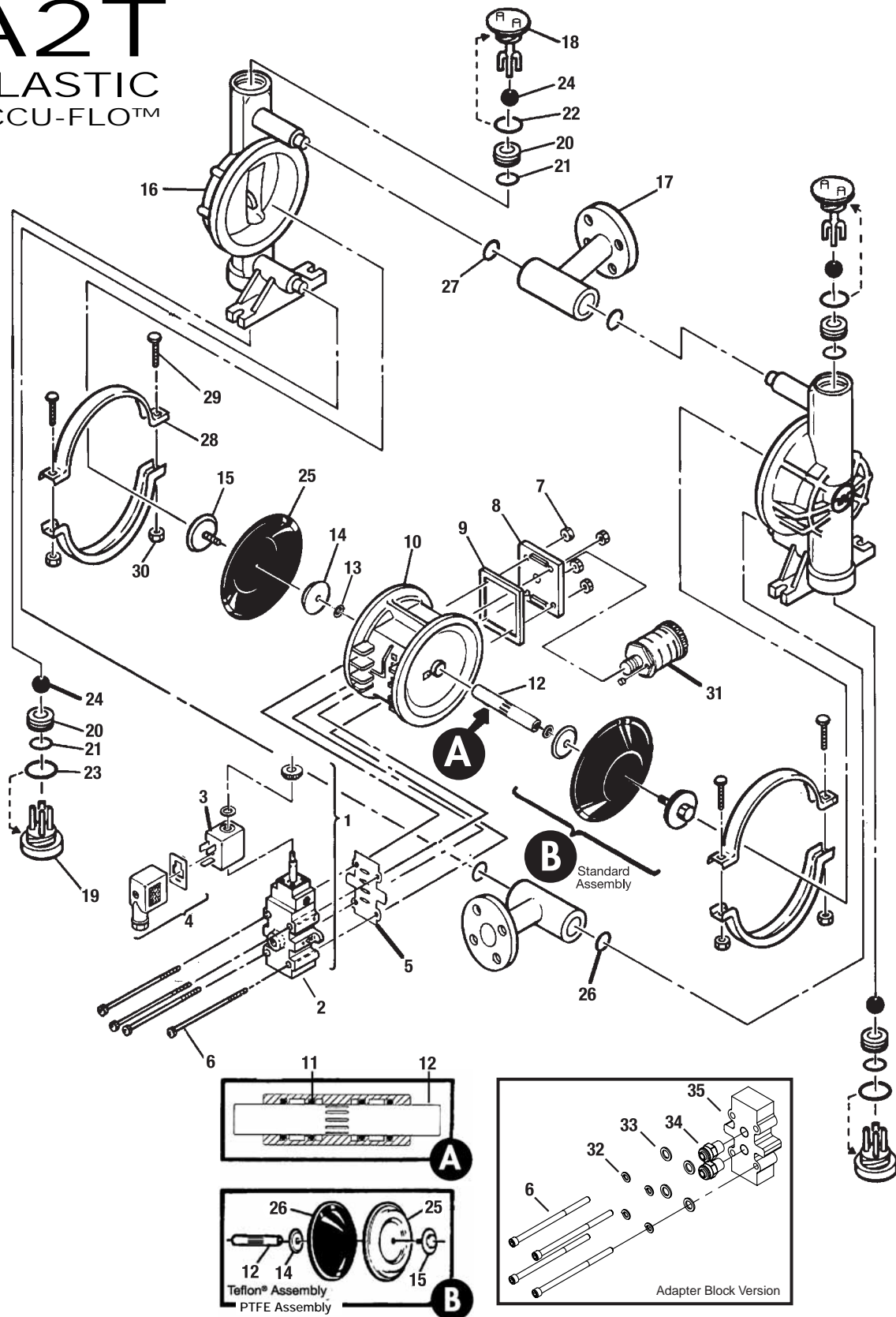

A2T ACCU-FLO™

Item No.	Part Description	Qty. Per Pump	RUBBER-FITTED		PTFE-FITTED	
			A2T/PKPPA/0263 P/N	A2T/KKPPA/0263 P/N	A2T/PKPPA/0263 P/N	A2T/KKPPA/0263 P/N
1	Solenoid Valve Assembly	1	02-2000-99-150	02-2000-99-150	02-2000-99-150	02-2000-99-150
2	Main Valve Body	1	02-2000-01-150	02-2000-01-150	02-2000-01-150	02-2000-01-150
3	Coil	1	00-2110-99-150	00-2110-99-150	00-2110-99-150	00-2110-99-150
4	Terminal Connector ²	1	00-2130-99	00-2130-99	00-2130-99	00-2130-99
5	Air Valve Gasket — Buna-N	1	02-2600-52	02-2600-52	02-2600-52	02-2600-52
6	Air Valve Bolt 1/4"-20 x 6-1/4"	4	02-6000-03	02-6000-03	02-6000-03	02-6000-03
7	Air Valve Nut 1/4"-20	4	04-6400-03	04-6400-03	04-6400-03	04-6400-03
8	Muffler Plate	1	02-3180-20	02-3180-20	02-3180-20	02-3180-20
9	Muffler Plate Gasket — Buna-N	1	02-3500-52-500	02-3500-52-500	02-3500-52-500	02-3500-52-500
10	Center Section	1	02-3151-20-225	02-3151-20-225	02-3151-20-225	02-3151-20-225
11	Center Section Glyd™ Ring	4	02-3210-55-225	02-3210-55-225	02-3210-55-225	02-3210-55-225
12	Shaft	1	02-3820-03-07	02-3820-03-07	02-3820-03-07	02-3820-03-07
13	Disc Spring	2	02-6802-08	02-6802-08	02-6802-08	02-6802-08
14	Inner Piston	2	02-3750-01	02-3750-01	02-3750-01	02-3750-01
15	Outer Piston	2	02-4550-21-500	02-4550-21-500	02-4600-21-500	02-4600-21-500
16	Liquid Chamber	2	02-5001-20-400	02-5001-21-400	02-5001-20-400	02-5001-21-400
17	Manifold Tee Section ¹	2	02-5160-20-400	02-5160-21-400	02-5160-20-400	02-5160-21-400
18	Top Retainer	2	02-5411-20-400	02-5411-21-400	02-5411-20-400	02-5411-21-400
19	Bottom Retainer	2	02-5420-20-400	02-5420-21-400	02-5420-20-400	02-5420-21-400
20	Valve Seat	4	02-1120-20-400	02-1120-21-400	02-1120-20-400	02-1120-21-400
21	Valve Seat O-Ring*	4	*	*	02-1200-60-400	02-1200-60-400
22	Top Retainer O-Ring*	2	*	*	02-1220-60	02-1220-60
23	Bottom Retainer O-Ring	2	*	*	02-1230-60	02-1230-60
24	Valve Ball*	4	*	*	02-1080-55	02-1080-55
25	Diaphragm*	2	*	*	02-1010-55	02-1010-55
26	Back-up Diaphragm	2	N/R	N/R	02-1060-51	02-1060-51
27	Tee Section O-Ring*	4	*	*	02-1300-60-400	02-1300-60-400
28	Clamp Band Assembly	2	02-7300-03-400	02-7300-03-400	02-7300-03-400	02-7300-03-400
29	Clamp Band Bolt 5/16"-18 x 1-3/4"	4	08-6050-03-500	08-6050-03-500	08-6050-03-500	08-6050-03-500
30	Clamp Band Nut 5/16"-18	4	08-6400-03	08-6400-03	08-6400-03	08-6400-03
31	Muffler	1	02-3510-99	02-3510-99	02-3510-99	02-3510-99
32	Lock Washer	4	50-6760-03	50-6760-03	50-6760-03	50-6760-03
33	Flat Washer	4	01-6730-03	01-6730-03	01-6730-03	01-6730-03
34	Air Fitting	2	00-2170-20	00-2170-20	00-2170-20	00-2170-20
35	Adapter Block	1	02-2150-XX	02-2150-XX	02-2150-XX	02-2150-XX
	Vent Plug (not shown)	1	02-7020-17	02-7020-17	02-7020-17	02-7020-17
	Expanded PTFE Gasket Kit (Not Shown)	1	N/R	N/R	02-9500-99	02-9500-99

¹DIN Flange: Polypropylene = 02-5160-20-404, PVDF = 02-5160-21-404

*Refer to corresponding elastomer chart in Section 10 for correct part number.

0263 Pump Specialty Code = Solenoid-Operated, 24V DC

²N/A for explosion proof.

All boldface items are primary wear parts.

Solenoid-Operated Valve Assembly Options (consists of valve body, coil and connector)

Pump Models Designating Specialty Code #	Part Number	Description
151	02-2000-99-151	24V AC / 12V DC Valve Assembly
153	02-2000-99-153	24V AC / 12V DC Valve Assembly (Nema 7)
150	02-2000-99-150	24V DC Valve Assembly
154	02-2000-99-154	24V DC Valve Assembly (Nema 7)
157	02-2000-99-157	International 24V DC Valve Assembly ¹
155	02-2000-99-155	110V AC Valve Assembly
156	02-2000-99-156	110V AC Valve Assembly (Nema 7)

Item 2 Main Valve Body Options

Part Number	Description
02-2000-01-150	Main Valve Body
02-2000-01-154	Main Valve Body (Nema 7)

Item 34 Adapter Block Options

Part Number	Description
01-2150-20	Polypropylene
01-2150-32	UHMW PE

Item 3 Coil Options

Pump Models Designating Specialty Code #	Part Number	Description
150	00-2110-99-150	24V DC Coil
151	00-2110-99-151	24V AC Coil
153	00-2110-99-153	24V AC, Nema 7 Coil
154	00-2110-99-154	24V DC, Nema 7 Coil
155	00-2110-99-155	110V AC Coil
156	00-2110-99-156	110V AC Nema 7 Coil
157	00-2110-99-157	International 24V DC Coil ¹

¹Meets European standards and regulations; CENELEC/PTB File #EX-91.C.2027.

SECTION 9B

EXPLODED VIEW/PARTS LISTING

A2P
PLASTIC
ACCU-FLO™

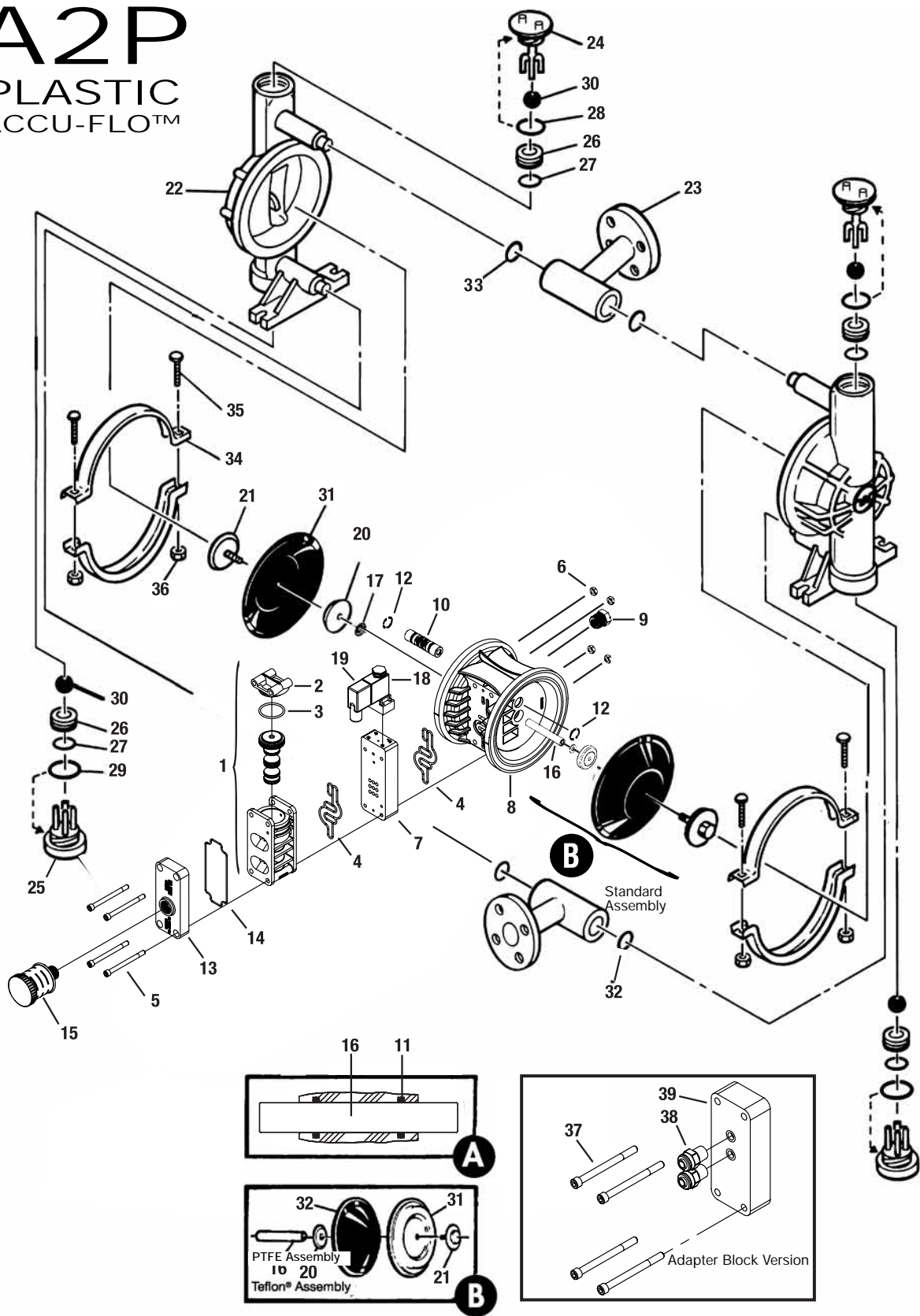

A2P ACCU-FLO™

Item No.	Part Description	Qty. Per Pump	RUBBER-FITTED		PTFE-FITTED	
			A2P/PKPPP/0263 P/N	A2P/KKPPP/0263 P/N	A2P/PKPPP/0263 P/N	A2P/KKPPP/0263 P/N
1	Pro-Flo® Air Valve Assembly	1	01-2010-20	01-2010-20	01-2010-20	01-2010-20
2	End Cap	1	01-2332-20	01-2332-20	01-2332-20	01-2332-20
3	O-Ring, End Cap	1	01-2395-52	01-2395-52	01-2395-52	01-2395-52
4	Gasket, Air Valve	2	01-2615-52	01-2615-52	01-2615-52	01-2615-52
5	Screw, HSHC, Air Valve	4	01-6000-03	01-6000-03	01-6000-03	01-6000-03
6	Nut, Hex	4	04-6400-03	04-6400-03	04-6400-03	04-6400-03
7	Pro-Flo® Solenoid Spacer	1	01-2160-20	01-2160-20	01-2160-20	01-2160-20
8	Center Section Assembly	1	02-3140-20	02-3140-20	02-3140-20	02-3140-20
9	Bushing Reducer	1	01-6950-20	01-6950-20	01-6950-20	01-6950-20
10	Pilot Sleeve Plug	1	02-2285-99	02-2285-99	02-2285-99	02-2285-99
11	Glyd™ Ring II	2	02-3210-55-225	02-3210-55-225	02-3210-55-225	02-3210-55-225
12	Retaining Ring	2	00-2650-03	00-2650-03	00-2650-03	00-2650-03
13	Muffler Plate	1	01-3181-20	01-3181-20	01-3181-20	01-3181-20
14	Gasket, Muffler Plate	1	01-3505-52	01-3505-52	01-3505-52	01-3505-52
15	Muffler	1	02-3510-99	02-3510-99	02-3510-99	02-3510-99
16	Shaft Pro-Flo®	1	02-3810-09	02-3810-09	02-3810-09	02-3810-09
17	Disc Spring	2	02-6802-08	02-6802-08	02-6802-08	02-6802-08
18	Coil	1	00-2110-99-150	00-2110-99-150	00-2110-99-150	00-2110-99-150
19	Terminal Connector	1	00-2130-99	00-2130-99	00-2130-99	00-2130-99
20	Inner Piston	2	02-3701-01	02-3701-01	02-3751-01	02-3751-01
21	Outer Piston	2	02-4550-21-500	02-4550-21-500	02-4600-21-500	02-4600-21-500
22	Liquid Chamber	2	02-5001-20-400	02-5001-21-400	02-5001-20-400	02-5001-21-400
23	Manifold Tee Section ²	2	02-5160-20-400	02-5160-21-400	02-5160-20-400	02-5160-21-400
24	Top Retainer	2	02-5411-20-400	02-5411-21-400	02-5411-20-400	02-5411-21-400
25	Bottom Retainer	2	02-5420-20-400	02-5420-21-400	02-5420-20-400	02-5420-21-400
26	Valve Seat	4	02-1120-20-400	02-1120-21-400	02-1120-20-400	02-1120-21-400
27	Valve Seat O-Ring*	4	*	*	02-1200-60-400	02-1200-60-400
28	Top Retainer O-Ring*	2	*	*	02-1220-60	02-1220-60
29	Bottom Retainer O-Ring	2	*	*	02-1230-60	02-1230-60
30	Valve Ball*	4	*	*	02-1080-55	02-1080-55
31	Diaphragm*	2	*	*	02-1010-55	02-1010-55
32	Back-up Diaphragm	2	N/R	N/R	02-1060-51	02-1060-51
33	Tee Section O-Ring*	4	*	*	02-1300-60-400	02-1300-60-400
34	Clamp Band Assembly	2	02-7300-03-400	02-7300-03-400	02-7300-03-400	02-7300-03-400
35	Clamp Band Bolt 5/16" - 18 x 1-3/4"	4	08-6050-03-500	08-6050-03-500	08-6050-03-500	08-6050-03-500
36	Clamp Band Nut 5/16" - 18	4	08-6400-03	08-6400-03	08-6400-03	08-6400-03
37	Air Valve Bolt	4	04-6000-03	04-6000-03	04-6000-03	04-6000-03
38	Fitting, Air Inlet	2	00-2170-20	00-2170-20	00-2170-20	00-2170-20
39	Adapter Block	1	00-2155-20	00-2155-20	00-2155-20	00-2155-20
	Expanded PTFE Gasket Kit (Not Shown)	1	N/R	N/R	02-9500-99	02-9500-99

¹DIN Flange: Polypropylene = 02-5160-20-404, PVDF = 02-5160-21-404

0263 Pump Specialty Code = Solenoid-Operated, 24V DC

*Refer to corresponding elastomer chart in Section 10 for correct part number.

All boldface items are primary wear parts.

Solenoid-Operated Valve Assembly Options (consists of valve body, coil and connector)

Pump Models Designating Specialty Code #	Part Number	Description
151	02-2000-99-151	24V AC / 12V DC Valve Assembly
153	02-2000-99-153	24V AC / 12V DC Valve Assembly (Nema 7)
150	02-2000-99-150	24V DC Valve Assembly
154	02-2000-99-154	24V DC Valve Assembly (Nema 7)
157	02-2000-99-157	International 24V DC Valve Assembly ¹
155	02-2000-99-155	110V AC Valve Assembly
156	02-2000-99-156	110V AC Valve Assembly (Nema 7)

Item 1 Main Valve Body Options

Part Number	Description
02-2000-01-150	Main Valve Body
02-2000-01-154	Main Valve Body (Nema 7)

Item 2 Coil Options

Pump Models Designating Specialty Code #	Part Number	Description
150	00-2110-99-150	24V DC Coil
151	00-2110-99-151	24V AC Coil
153	00-2110-99-153	24V AC, Nema 7 Coil
154	00-2110-99-154	24V DC, Nema 7 Coil
155	00-2110-99-155	110V AC Coil
156	00-2110-99-156	110V AC Nema 7 Coil
157	00-2110-99-157	International 24V DC Coil ¹

¹Meets European standards and regulations; CENELEC/PTB File #EX-91.C.2027.

SECTION 10A

ELASTOMER OPTIONS

A2 PUMPS

MATERIAL	Color Code	DIAPHRAGM P/N (2)	VALVE BALL P/N (4)	VALVE SEAT* O-RING P/N (4)	TEE SECTION O-RING P/N (4)	TOP RETAINER O-RING P/N (2)	BOTTOM RETAINER O-RING P/N (2)
Polyurethane	Natural	02-1010-50	02-1080-50	02-1200-50-400	02-1300-50-400	02-1220-50	02-1230-50
Buna-N	Red	02-1010-52	02-1080-52	08-2390-52	04-2390-52	04-2390-52-700	02-1230-52
PTFE Encapsulated Viton®	None	N/A	N/A	02-1200-60-400	02-1300-60-400	02-1220-60	02-1230-60
Neoprene	Green	02-1010-51	02-1080-51	N/A	N/A	N/A	N/A
Viton®	Silver	02-1010-53	02-1080-53	N/A	N/A	N/A	N/A
EPDM	Blue	02-1010-54	02-1080-54	N/A	N/A	N/A	N/A
PTFE	White	02-1010-55	02-1080-55	N/A	N/A	N/A	N/A
Saniflex™	Off-White	02-1010-56	02-1080-56	N/A	N/A	N/A	N/A
Wil-Flex™	Orange	02-1010-58	02-1080-58	02-1200-58-400	02-1300-58-400	02-1220-58	02-1230-58
Neoprene Backup	Black	02-1060-511	N/A	N/A	N/A	N/A	N/A

1. Saniflex™ back-up diaphragms, P/N 02-1060-56, are available upon request. Please consult your local distributor.

*NOTE: Rubber valve seats do not require an O-ring.

SECTION 10B

ELECTRICAL INFORMATION

NEMA 4 / UL / CSA

Part Number	Voltage ±10%			Power (W) ±10%	Current (A)			Resistivity (Ω)
	DC	AC			DC	AC		
		60 Hz	50 Hz			Inrush	Holding	
00-2110-99-150	24	48	44	4.8	.20	.20	.20	121
00-2110-99-151	12	24	22	4.8	.40	.40	.40	32
00-2110-99-155	60	120	110	4.8	.08	.08	.06	840

NEMA 7 / UL / CSA

Part Number	Voltage ±10%			Power (W) ±10%	Current (A)			Resistivity (Ω)
	DC	AC			DC	AC		
		60 Hz	50 Hz			Inrush	Holding	
00-2110-99-153	12	24	22	7	.60	.55	.32	19
00-2110-99-154	24	48	44	7	.30	.30	.18	75
00-2110-99-156	60	120	110	7	.12	.13	.06	475

INTERNATIONAL EXPLOSION PROOF / CENELEC / PTB FILE # EX-91.C.2027

Part Number	DC Voltage ±10%	Power (W) ±10%	Current (A)		Resistivity (Ω)
			Inrush	Holding	
00-2110-99-157	24	3.3	.135	.135	177

WARRANTY

Each and every product manufactured by Wilden Pump and Engineering, LLC is built to meet the highest standards of quality. Every pump is functionally tested to insure integrity of operation.

Wilden Pump and Engineering, LLC warrants that pumps, accessories and parts manufactured or supplied by it to be free from defects in material and workmanship for a period of five (5) years from date of installation or six (6) years from date of manufacture, whichever comes first. Failure due to normal wear, misapplication, or abuse is, of course, excluded from this warranty.

Since the use of Wilden pumps and parts is beyond our control, we cannot guarantee the suitability of any pump or part for a particular application and Wilden Pump and Engineering, LLC shall not be liable for any consequential damage or expense arising from the use or misuse of its products on any application. Responsibility is limited solely to replacement or repair of defective Wilden pumps and parts.

All decisions as to the cause of failure are the sole determination of Wilden Pump and Engineering, LLC.

Prior approval must be obtained from Wilden for return of any items for warranty consideration and must be accompanied by the appropriate MSDS for the product(s) involved. A Return Goods Tag, obtained from an authorized Wilden distributor, must be included with the items which must be shipped freight prepaid.

The foregoing warranty is exclusive and in lieu of all other warranties expressed or implied (whether written or oral) including all implied warranties of merchantability and fitness for any particular purpose. No distributor or other person is authorized to assume any liability or obligation for Wilden Pump and Engineering, LLC other than expressly provided herein.

PLEASE PRINT OR TYPE AND FAX TO WILDEN

PUMP INFORMATION			
Item # _____		Serial # _____	
Company Where Purchased _____			
YOUR INFORMATION			
Company Name _____			
Industry _____			
Name _____		Title _____	
Street Address _____			
City _____		State _____	Postal Code _____
Country _____			
Telephone _____		Fax _____	E-mail _____
Web Address _____			
Number of pumps in facility? _____		Number of Wilden pumps? _____	
Types of pumps in facility (check all that apply): <input type="checkbox"/> Diaphragm <input type="checkbox"/> Centrifugal <input type="checkbox"/> Gear <input type="checkbox"/> Submersible <input type="checkbox"/> Lobe			
<input type="checkbox"/> Other _____			
Media being pumped? _____			
How did you hear of Wilden Pump? <input type="checkbox"/> Trade Journal <input type="checkbox"/> Trade Show <input type="checkbox"/> Internet/E-mail <input type="checkbox"/> Distributor			
<input type="checkbox"/> Other _____			

ONCE COMPLETE, FAX TO (909) 783-3440

NOTE: WARRANTY VOID IF PAGE IS NOT FAXED TO WILDEN

WILDEN PUMP & ENGINEERING, LLC