

CR(E), CRI(E), CRN(E) 3

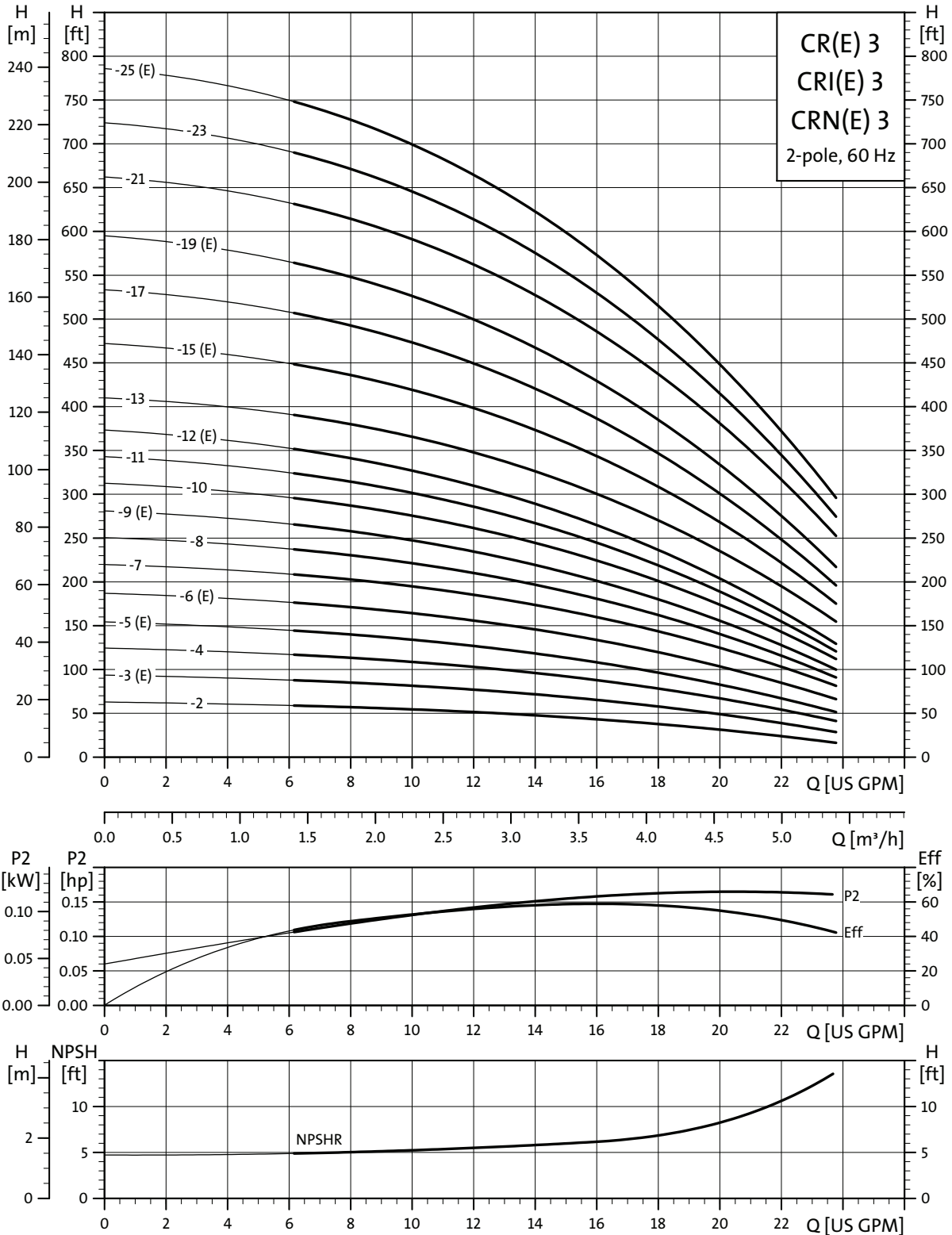

TM02 4084 1303

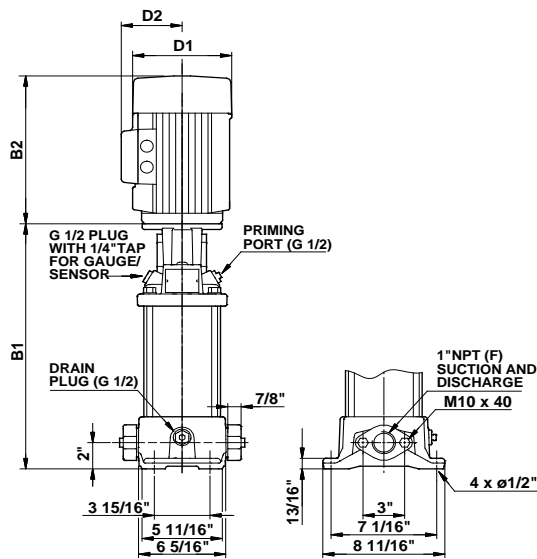

TM03 1450 2205

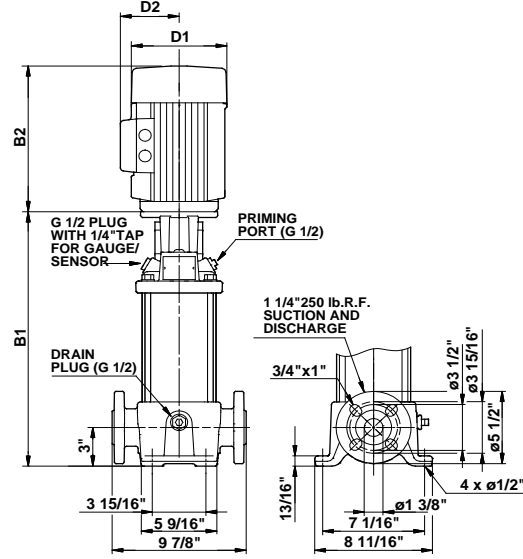

TM03 1451 2205

Pump type	P2 [hp]	Ph.	Oval*	ANSI dimensions [inch]					Ship Wt. [lbs.]	ANSI dimensions [inch]			
				B1	TEFC			Ship Wt. [lbs.]		MLE			
					D1	D2	B1+B2			D1	D2	B1+B2	
CR 3-2	1/3	1	•	12	6 1/4	5	21 3/8	69	-	-	-	-	
		3	•	12	5 5/8	4 5/8	19 5/8	67	-	-	-	-	
CR(E) 3-3	1/2	1	•	12	6 1/4	5	21 3/8	73	5 1/2	5 1/2	19 1/2	70	
		3	•	12	5 5/8	4 5/8	19 5/8	67	-	-	-	-	
CR 3-4	3/4	1	•	12 3/4	6 1/4	5	22 5/8	78	-	-	-	-	
		3	•	12 3/4	5 5/8	4 5/8	20 3/8	69	-	-	-	-	
CR(E) 3-5	3/4	1	•	13 1/2	6 1/4	5	23 3/8	79	5 1/2	5 1/2	21	73	
		3	•	13 1/2	5 5/8	4 5/8	21	70	-	-	-	-	
CR(E) 3-6	1	1	•	14 1/8	7 1/4	5 3/4	25 3/8	91	5 1/2	5 1/2	23 1/4	77	
		3	•	14 1/8	5 5/8	4 5/8	21 3/4	71	7	6 5/8	27 1/8	90	
CR 3-7	1 1/2	1	•	14 7/8	7 1/4	5 3/4	26 1/2	95	-	-	-	-	
		3	•	14 7/8	5 5/8	4 5/8	23 5/8	72	-	-	-	-	
CR 3-8	1 1/2	1	•	15 5/8	7 1/4	5 3/4	27 1/4	96	-	-	-	-	
		3	•	15 5/8	5 5/8	4 5/8	24 3/8	73	-	-	-	-	
CR(E) 3-9	1 1/2	1	•	16 1/4	7 1/4	5 3/4	28	97	5 1/2	5 1/2	25 3/8	82	
		3	•	16 1/4	5 5/8	4 5/8	25	74	7	6 5/8	29 1/4	99	
CR 3-10	2	1	•	17	7 1/4	5 3/4	29 5/8	109	-	-	-	-	
		3	•	17	7 1/8	4 3/8	28 3/8	96	-	-	-	-	
CR 3-11	2	1	•	17 3/4	7 1/4	5 3/4	30 1/4	110	-	-	-	-	
		3	•	17 3/4	7 1/8	4 3/8	29 1/8	101	-	-	-	-	
CR(E) 3-12	2	1	•	18 3/8	7 1/4	5 3/4	31	111	-	-	-	-	
		3	•	18 3/8	7 1/8	4 3/8	29 3/4	102	7	6 5/8	31 3/8	115	
CR 3-13	3	1	•	20 1/4	8 5/8	6 7/8	34 5/8	147	-	-	-	-	
		3	•	20 1/4	7 1/8	4 3/8	31 7/8	108	-	-	-	-	
CR(E) 3-15	3	1	•	21 5/8	8 5/8	6 7/8	36	149	-	-	-	-	
		3	•	21 5/8	7 1/8	4 3/8	33 1/4	110	8 3/4	7 1/2	35	128	
CR 3-17	3	1	•	23	8 5/8	6 7/8	37 1/2	150	-	-	-	-	
		3	•	23	7 1/8	4 3/8	34 3/4	111	-	-	-	-	
CR(E) 3-19	3	1	-	24 1/2	8 5/8	6 7/8	38 7/8	156	-	-	-	-	
		3	-	24 1/2	7 1/8	4 3/8	36 1/8	113	8 3/4	7 1/2	37 3/4	132	
CR 3-21	5	1	-	25 7/8	10 5/8	7 1/2	41 1/4	185	-	-	-	-	
		3	-	25 7/8	7 1/8	4 3/8	39 1/8	128	-	-	-	-	
CR 3-23	5	1	-	27 1/4	10 5/8	7 1/2	42 5/8	187	-	-	-	-	
		3	-	27 1/4	7 1/8	4 3/8	40 1/2	130	-	-	-	-	
CR(E) 3-25	5	1	-	28 3/4	10 5/8	7 1/2	44	189	-	-	-	-	
		3	-	28 3/4	7 1/8	4 3/8	42	132	8 3/4	7 1/2	44 1/4	172	

All dimensions in inches unless otherwise noted.

*Oval flanged pump B1 and B1+B2 dimension is one inch less than ANSI flanged pump and weight is approximately 9 lbs. less.

• Available.

Technical data

CRN(E) 3

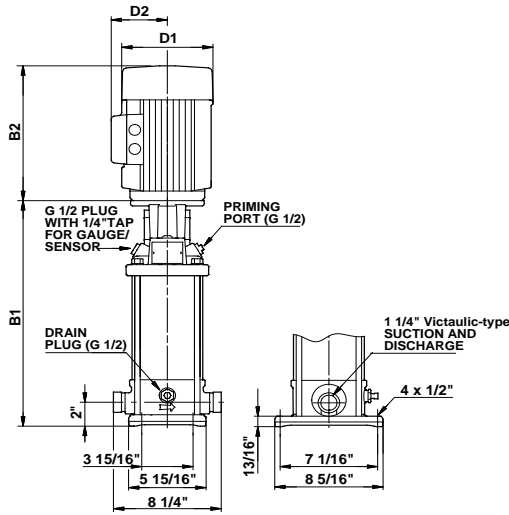

TM03 1454 2205

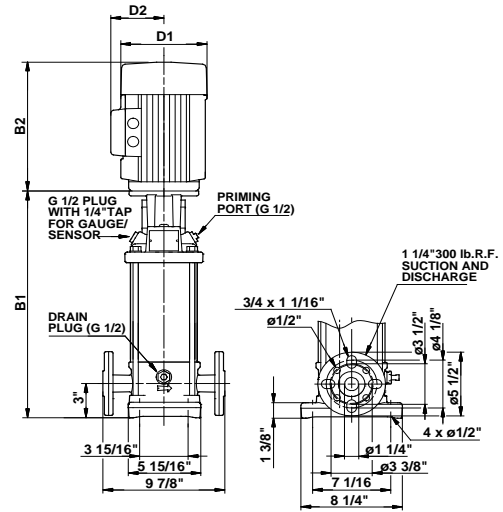

TM03 1453 2205

Pump type	P2 [hp]	Ph.	PJE*	ANSI dimensions [inch]				Ship Wt. [lbs.]	ANSI dimensions [inch]			
				B1	TEFC				MLE			Ship Wt. [lbs.]
					D1	D2	B1+B2		D1	D2	B1+B2	
CRN 3-2	1/3	1	•	12 1/8	6 1/4	5	21 1/2	64	-	-	-	-
		3	•	12 1/8	5 5/8	4 5/8	19 3/4	62	-	-	-	-
CRN(E) 3-3	1/2	1	•	12 1/8	6 1/4	5	21 1/2	67	5 1/2	5 1/2	19 5/8	65
		3	•	12 1/8	5 5/8	4 5/8	19 3/4	62	-	-	-	-
CRN 3-4	3/4	1	•	12 7/8	6 1/4	5	22 3/4	73	-	-	-	-
		3	•	12 7/8	5 5/8	4 5/8	20 1/2	63	-	-	-	-
CRN(E) 3-5	3/4	1	•	13 1/2	6 1/4	5	23 1/2	73	5 1/2	5 1/2	21 1/8	68
		3	•	13 1/2	5 5/8	4 5/8	21 1/8	64	-	-	-	-
CRN(E) 3-6	1	1	•	14 1/4	7 1/4	5 3/4	25 1/2	86	5 1/2	5 1/2	23 3/8	71
		3	•	14 1/4	5 5/8	4 5/8	21 7/8	65	7	6 5/8	27 1/4	85
CRN 3-7	1 1/2	1	•	15	7 1/4	5 3/4	26 5/8	90	-	-	-	-
		3	•	15	5 5/8	4 5/8	23 3/4	67	-	-	-	-
CRN 3-8	1 1/2	1	•	15 3/4	7 1/4	5 3/4	27 3/8	91	-	-	-	-
		3	•	15 3/4	5 5/8	4 5/8	24 1/2	68	-	-	-	-
CRN(E) 3-9	1 1/2	1	•	16 3/8	7 1/4	5 3/4	28 1/8	92	5 1/2	5 1/2	25 1/2	77
		3	•	16 3/8	5 5/8	4 5/8	25 1/8	69	7	6 5/8	29 3/8	93
CRN 3-10	2	1	•	17 1/8	7 1/4	5 3/4	29 3/4	104	-	-	-	-
		3	•	17 1/8	7 1/8	4 3/8	28 1/2	91	-	-	-	-
CRN 3-11	2	1	•	17 7/8	7 1/4	5 3/4	30 3/8	105	-	-	-	-
		3	•	17 7/8	7 1/8	4 3/8	29 1/4	95	-	-	-	-
CRN(E) 3-12	2	1	•	18 1/2	7 1/4	5 3/4	31 1/8	106	-	-	-	-
		3	•	18 1/2	7 1/8	4 3/8	29 7/8	96	7	6 5/8	31 1/2	109
CRN 3-13	3	1	•	20 3/8	8 5/8	6 7/8	34 3/4	139	-	-	-	-
		3	•	20 3/8	7 1/8	4 3/8	32	100	-	-	-	-
CRN(E) 3-15	3	1	•	21 3/4	8 5/8	6 7/8	36 1/8	141	-	-	-	-
		3	•	21 3/4	7 1/8	4 3/8	33 3/8	102	8 3/4	7 1/2	35 1/8	123
CRN 3-17	3	1	•	23 1/8	8 5/8	6 7/8	37 5/8	143	-	-	-	-
		3	•	23 1/8	7 1/8	4 3/8	34 7/8	104	-	-	-	-
CRN(E) 3-19	3	1	•	24 5/8	8 5/8	6 7/8	39	148	-	-	-	-
		3	•	24 5/8	7 1/8	4 3/8	36 1/4	106	8 3/4	7 1/2	37 7/8	124
CRN 3-21	5	1	•	26	10 5/8	7 1/2	41 3/8	178	-	-	-	-
		3	•	26	7 1/8	4 3/8	39 1/4	121	-	-	-	-
CRN 3-23	5	1	•	27 3/8	10 5/8	7 1/2	42 3/4	180	-	-	-	-
		3	•	27 3/8	7 1/8	4 3/8	40 5/8	122	-	-	-	-
CRN(E) 3-25	5	1	•	28 7/8	10 5/8	7 1/2	44 1/8	182	-	-	-	-
		3	•	28 7/8	7 1/8	4 3/8	42 1/8	124	8 3/4	7 1/2	44 3/8	165

All dimensions in inches unless otherwise noted.

*PJE flanged pump B1 and B1+B2 dimension is one inch less than ANSI flanged pump and weight is approximately 9 lbs. less.

• Available.