

10EC SERIES - 1/2 HP

APPLICATIONS

Effluent wastewater removal, dewatering, water transfer

FEATURES

- Heavy-duty cast iron construction
- Permanent Split Capacitor (PSC)
- Designed for continuous duty
- Energy-saving low amp draw
- 1-1/2" FNPT (38 mm) discharge
- Handles solids up to 1/2" (12.7 mm) diameter
- Multiple switch options for automatic operation
- 140 °F (60 °C) liquid temperature rating
- cCSAus listed



SERIES SPECIFICATIONS

Volts	Hz	Amps	Watts	Performance (GPM at Height in Feet)					Shut-Off (ft)	PSI
				5'	10'	15'	20'	30'		
115	60	6.5	750	67	57	52	47	28	36	15.6
230	60	3.5	750	67	57	52	47	28	36	15.6

Item	Model	HP	Volts	Base Material	Switch Type/ Operations	On Level	Off Level	Cord	Weight
510852	10EC-CIA-RF	1/2	115	Cast Iron	Piggyback Mechanical Float	13" - 15" 33.2 cm - 38.1 cm	6" - 8" 15.2 cm - 20.3 cm	20' 6.1 m	36.5 lbs 16.6 Kg
510851	10EC-CIA-SFS	1/2	115	Cast Iron	Integral Snap-Action Float	8" - 11" 20.3 cm - 27.9 cm	2" - 5" 5.1 cm - 12.7 cm	10' 3 m	35 lbs 15.9 Kg
510803	10EC-CIA-SFS	1/2	115	Polypropylene	Integral Snap-Action Float	8" - 11" 20.3 cm - 27.9 cm	2" - 5" 5.1 cm - 12.7 cm	10' 3 m	29 lbs 13.5 Kg
510854	10EC-CIA-SFS	1/2	115	Cast Iron	Integral Snap-Action Float	8" - 11" 20.3 cm - 27.9 cm	2" - 5" 5.1 cm - 12.7 cm	20' 6.1 m	36 lbs 16.3 Kg
510802	10EC-CIA-SFS	1/2	115	Polypropylene	Integral Snap-Action Float	8" - 11" 20.3 cm - 27.9 cm	2" - 5" 5.1 cm - 12.7 cm	20' 6.1 m	30 lbs 13.6 Kg
510801	10EC-CIM	1/2	115	Polypropylene	Manual	—	—	10' 3 m	27.5 lbs 12.5 Kg
510850	10EC-CIM	1/2	115	Cast Iron	Manual	—	—	20' 6.1 m	33.5 lbs 15.2 Kg
510800	10EC-CIM	1/2	115	Polypropylene	Manual	—	—	20' 6.1 m	28.5 lbs 12.9 Kg

EFFLUENT PUMPS

10EC SERIES - 1/2 HP

ENGINEERING DATA

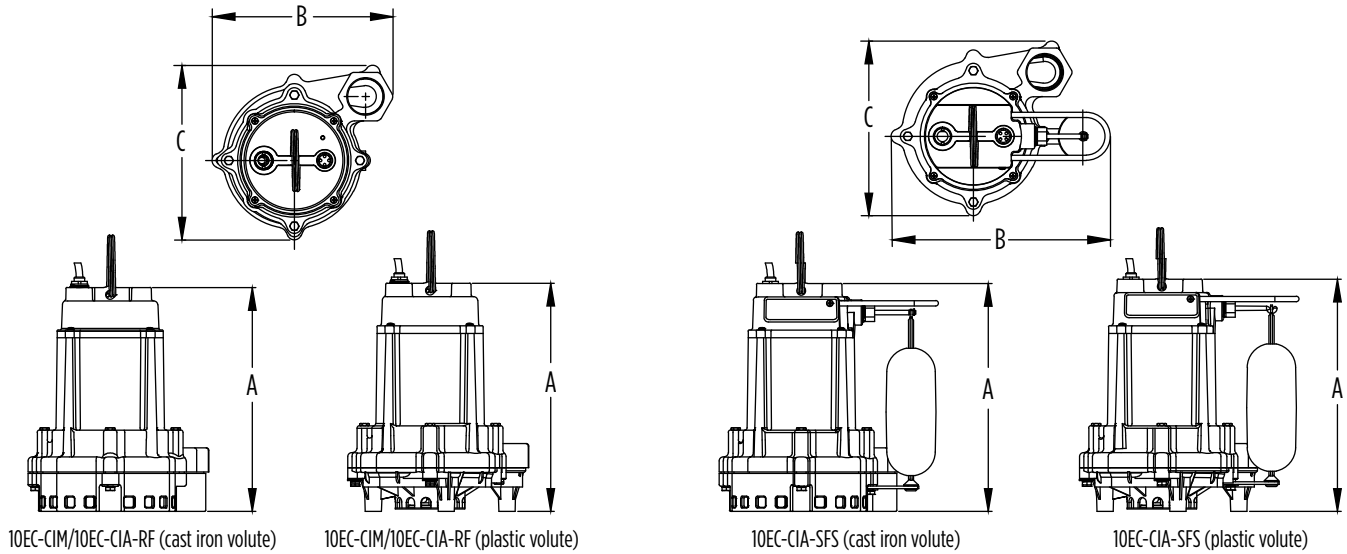

Model	Base	A	B	C
10EC-CIA-SFS	Polypropylene	11.28" (286.5 mm)	10.66" (270.8 mm)	8.48" (215.5 mm)
	Cast Iron	11.07" (281.2 mm)	10.66" (270.8 mm)	8.48" (215.5 mm)
10EC-CIA-RF	Cast Iron	10.9" (276.2 mm)	8.79" (223.4 mm)	8.48" (215.5 mm)
10EC-CIM	Polypropylene	11.08" (281.5 mm)	8.79" (223.4 mm)	8.48" (215.5 mm)
	Cast Iron	10.9" (276.2 mm)	8.79" (223.4 mm)	8.48" (215.5 mm)

PERFORMANCE DATA

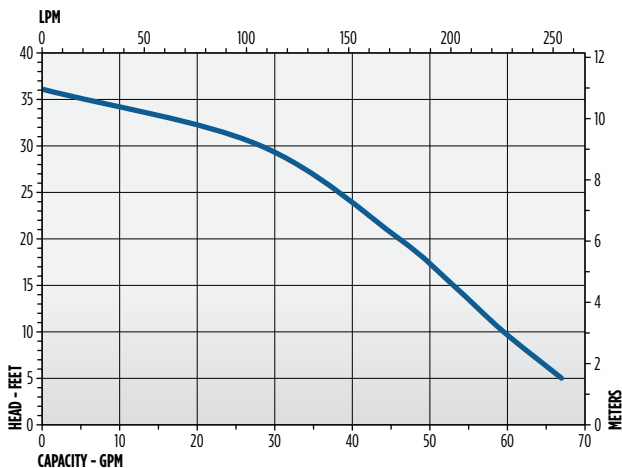

CONSTRUCTION

Cover	Epoxy-coated cast iron
Motor Housing	Epoxy-coated cast iron
Impeller Material	Nylon
Volute	Epoxy-coated cast iron
Mechanical Shaft Seal	Nitrile with carbon and ceramic faces
Fasteners	Stainless steel
Shaft	Cold-rolled steel
Bearings	Upper and lower ball bearings
Power Cord	SJTW