

MAGNA 32-60

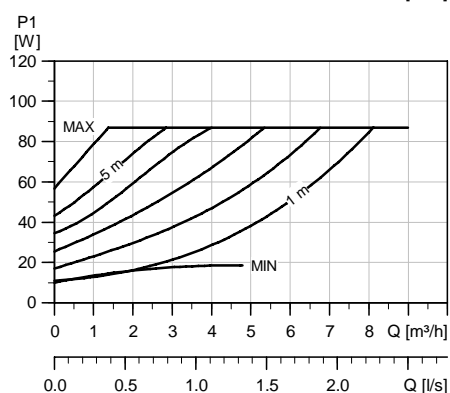

Datos eléctricos

U_n [V]		P_1 [W]	I_n [A]
1 x 230-240 V	Mín.	10	0,09
	Máx.	85	0,6

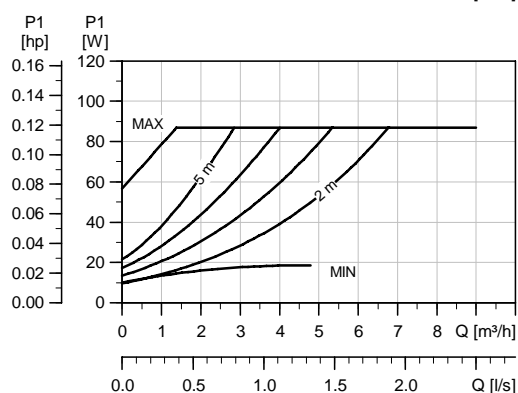
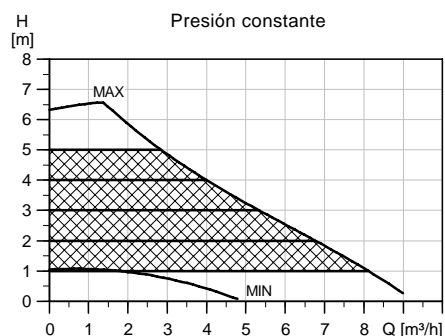
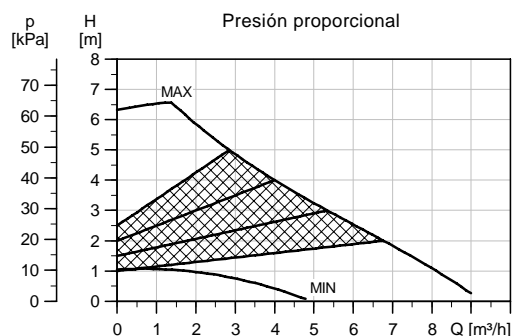
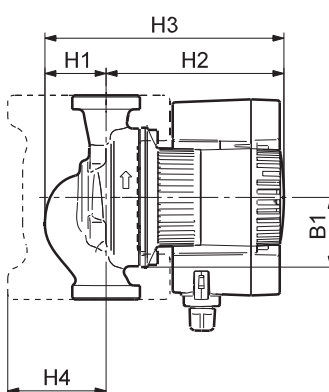
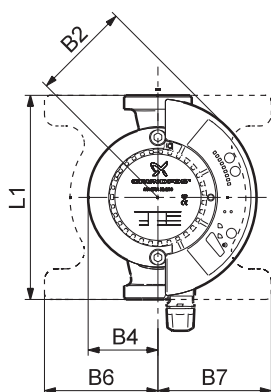

Dimensiones y pesos

Tipo de bomba PN 6 / PN 10	Dimensiones [mm]											Peso [kg] Bruto	Volumen [m³]	
	L1	B1	B2	B4	B6	B7	H1	H2	H3	H4	D1			G
MAGNA 32-60	180	62	87	62	100	100	54	157	211	85	32	2	5,6	0,91

MAGNA 32-100 (N)

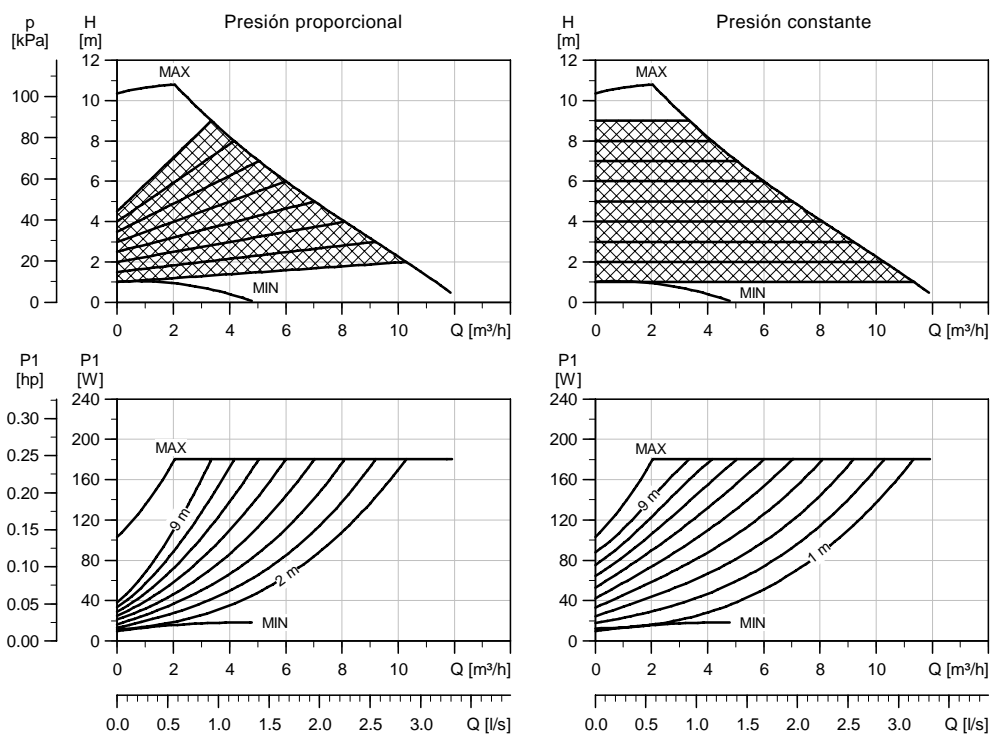

TM03 1849 3205

Datos eléctricos

U_n [V]	P_1 [W]	I_n [A]
1 x 230-240 V	Mín.	10
	Máx.	180

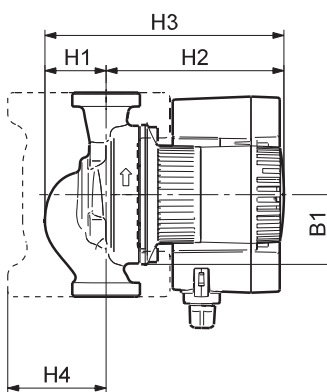
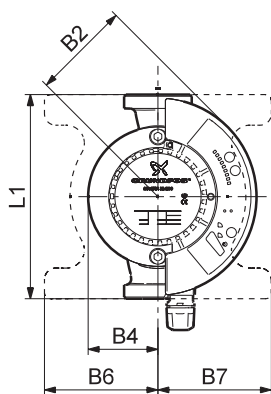

TM03 1234 1405

Dimensiones y pesos

Tipo de bomba	Dimensiones [mm]												Peso [kg]		Volumen [m³]
	L1	B1	B2	B4	B6	B7	H1	H2	H3	H4	D1	G	Bruto	(N)	
MAGNA 32-100 (N)	180	62	87	62	100	100	54	157	211	85	32	2	5,6	6,0 (N)	0,91