

MTA 200

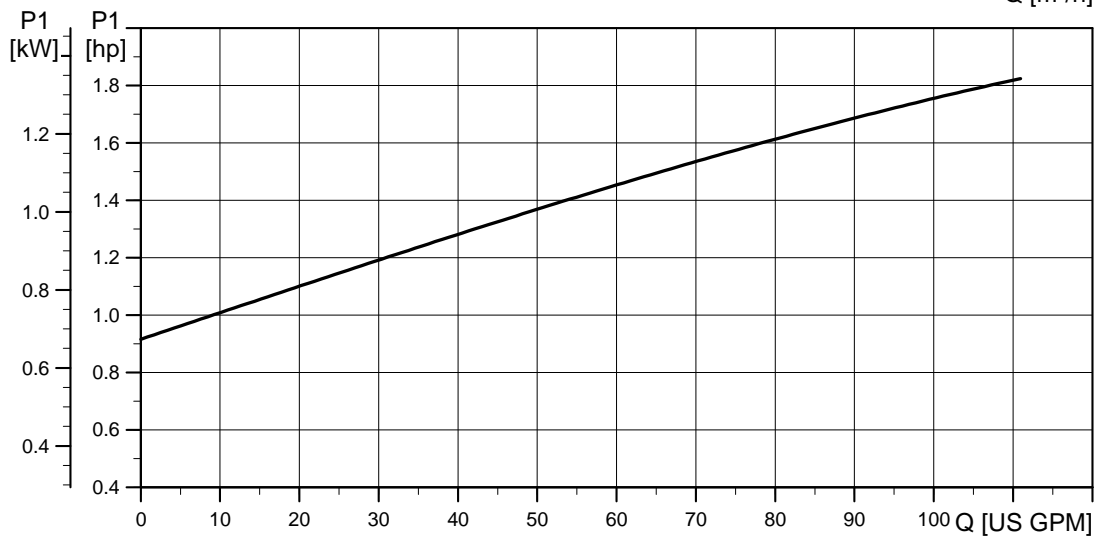

Dimensional sketches

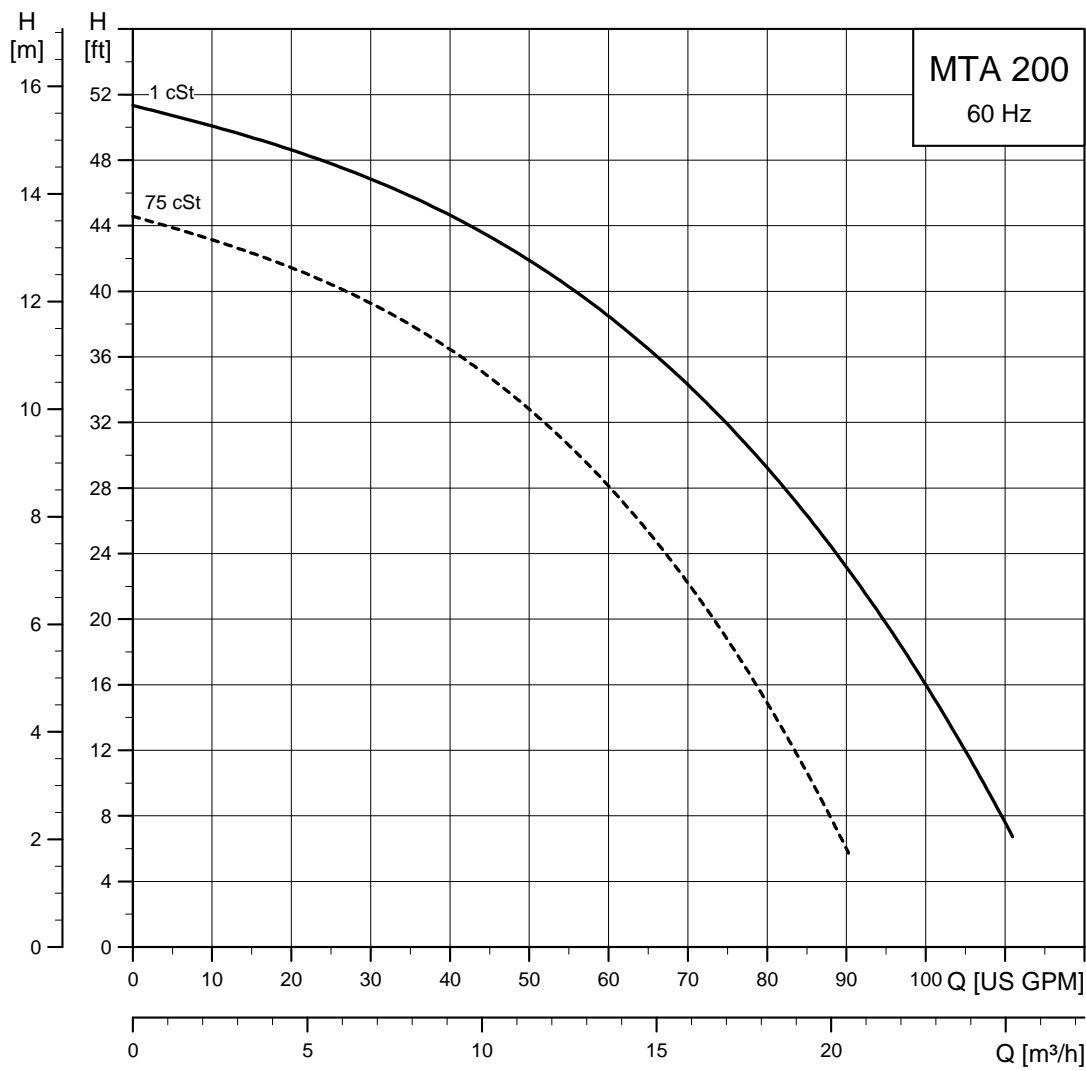
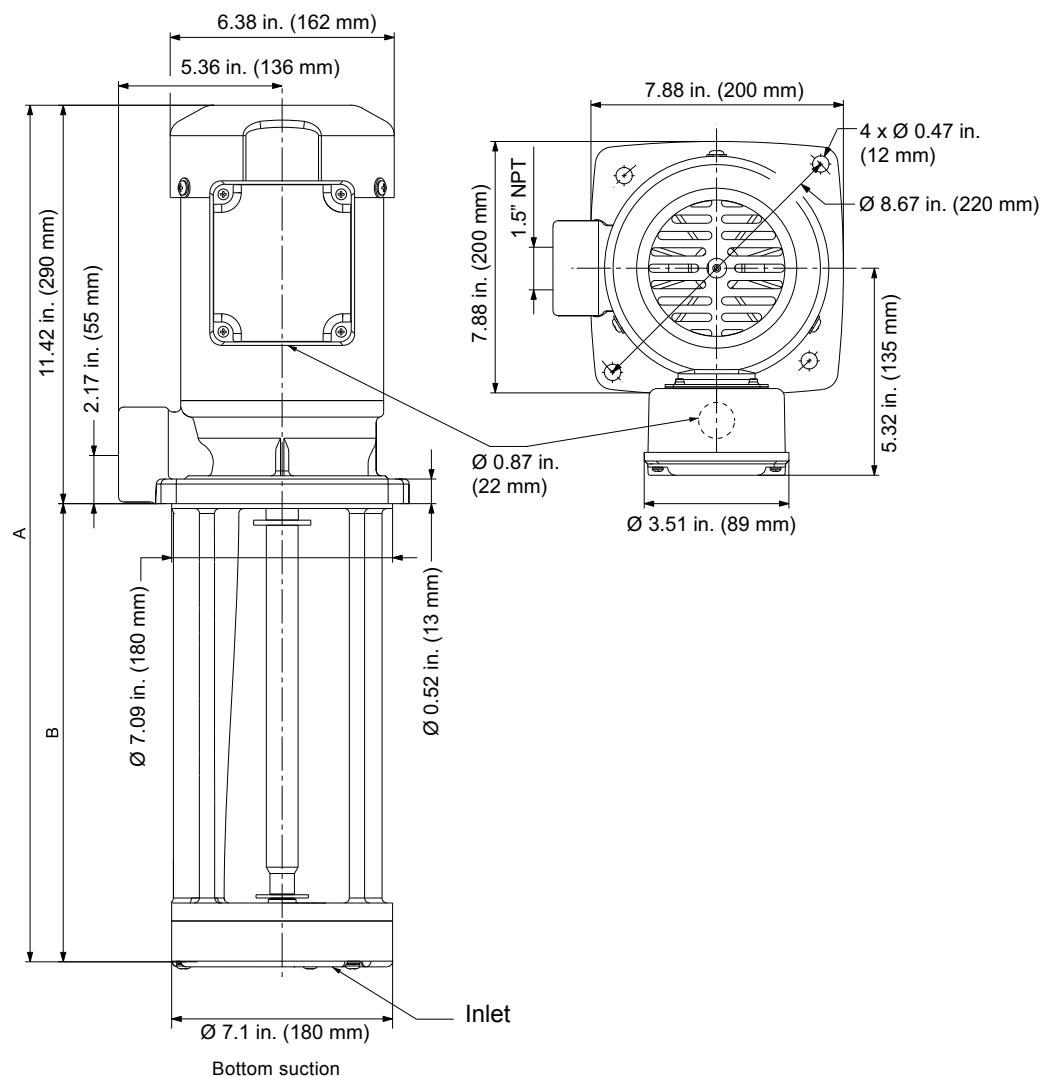

TM05 4997 3412

Dimensions and weights

Pump type	Suction	A [in. (mm)]	B [in. (mm)]	Ship weight [lb]
MTA 200-250	Bottom	21.26 (540)	9.85 (250)	60
MTA 200-280		22.45 (570)	11.03 (280)	61
MTA 200-350		25.20 (640)	13.78 (350)	64

Electrical data

Voltage	Frequency [Hz]	P1 [W]	I _{1/1} [A]	I _{max} [A]	I _{start} / I _{1/1} [A]	Cos φ
3 x 200Δ V	60	1340	4.28 - 4.28	4.92 - 4.92	5.0 - 5.5	0.90 - 0.82
3 x 220-240Δ/380-440Y V	60	1270	3.48 / 2.11-1.96	4.0 / 2.43-2.25	5.0 - 5.5	0.96 - 0.88