

Posición	Contar	Descripción
	1	<p>PRODNAME}</p>  <p style="text-align: center;">Advertencia! la foto puede diferir del actual producto</p> <p>Código: 91136145 Single-stage, centrifugal, in-line, single-head pump.</p> <p>The in-line design with opposite suction and discharge ports enables mounting in pipework or on a concrete foundation.</p> <p>The shaft seal is a corrosion resistant maintenance-free mechanical seal.</p> <p>The pump is fitted with a three-phase MLE motor with frequency converter and PI-controller integrated in the motor terminal box. No additional motor protection is required as both motor and electronics are protected by integrated overload and temperature protection.</p> <p>A differential pressure transmitter fitted on the pump registers the differential pressure across the pump and enables constant pressure or proportional pressure control of the pump.</p> <p>A control panel enables setting of required setpoint as well as setting of pump to MIN or MAX operation or to STOP. The control panel has indicator lights for "Operation" and "Fault".</p> <p>Communication with the pump is possible by means of Grundfos R100 Remote Control enabling further settings as well as reading out of a number of parameters such as "Actual value", "Speed", "Power input" and total "Power consumption".</p> <p>The terminal box holds terminals for the connection of :</p> <ul style="list-style-type: none"> - Pump start/stop (potential-free contact), - external remote setpoint setting via analog signal, 0 - 5 V, 0 - 10 V, 0(4) - 20 mA, - 5 V voltage supply for setpoint potentiometer, I_{max} = 5 mA, - differential pressure sensor factory-fitted, - input for forced control to MIN or MAX (potential-free contact), - potential-free fault signal relay with changeover contact, - RS485 GENIbus.

91136145 TPE 100-40/4 60 Hz

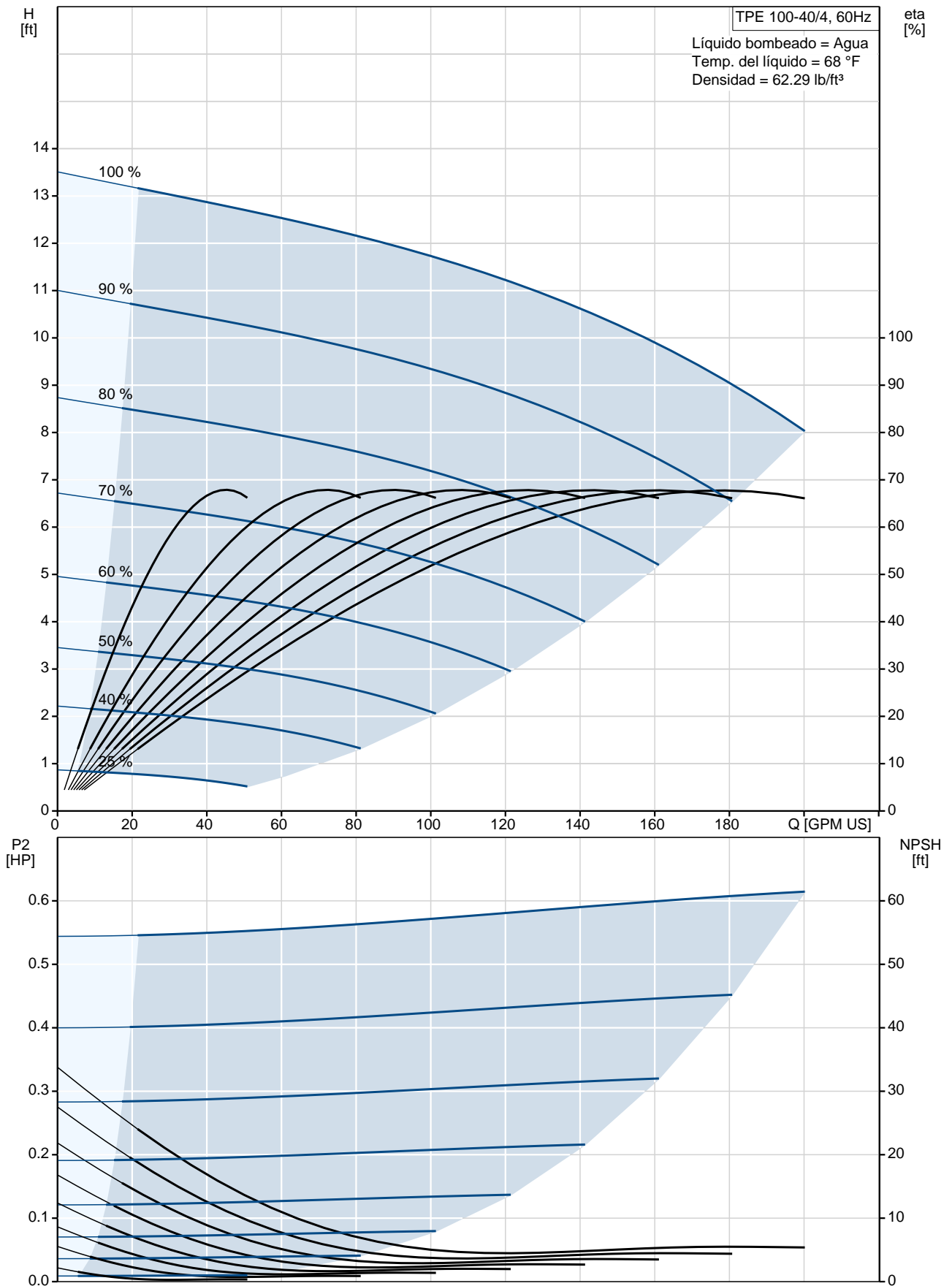

Descripción	Valor
Información general:	
Producto::	TPE 100-40/4 U-G-A-BUBE
Código::	91136145
Número EAN::	5700832184934
Precio:	Bajo pedido
Técnico:	
Velocidad para datos de bomba:	1725 rpm
Caudal nominal:	176 GPM US
Altura nominal:	9.187 ft
Altura máxima:	13.12 ft
Código del cierre. 1:Tipo 2:Cara giratoria 3:Cara estacionaria 4:Cierre secunda.:	BUBE
Bomba N°:	96405277
Versión de la bomba:	U
Materiales:	
Cuerpo hidráulico:	Fundición EN-JL 1040 ASTM 25 B
Impulsor:	Acero inoxidable DIN W.-Nr. 1.4301 AISI 304
Código de material:	A
Instalación:	
Temperatura ambiental máxima:	104 °F
Presión de trabajo máxima:	145 psi
Tipo de brida:	ANSI
Código de conexión:	G
Diámetro de conexiones:	4"
Presión:	Class 125
Tamaño de la brida del motor:	56C
Líquido:	
Líquido bombeado:	Agua
Rango de temperatura del líquido:	5 .. 284 °F
Temp. líquido:	68 °F
Densidad:	62.29 lb/ft³
Datos eléctricos:	
Tipo de motor:	80BA
Potencia nominal - P2:	1 HP
Frecuencia de alimentación:	60 Hz
Tensión nominal:	1 x 208-230 V
Corriente nominal:	5,40-4,90 A
Cos phi - Factor de potencia:	0,97
Velocidad nominal:	180-1690 rpm
Número de polos:	4
Grado de protección (IEC 34-5):	IP55
Clase de aislamiento (IEC 85):	F
Protección del motor:	PTC
Motor N°:	86765104
Otros:	
Peso bruto:	140 lb
Programa N°:	96059357

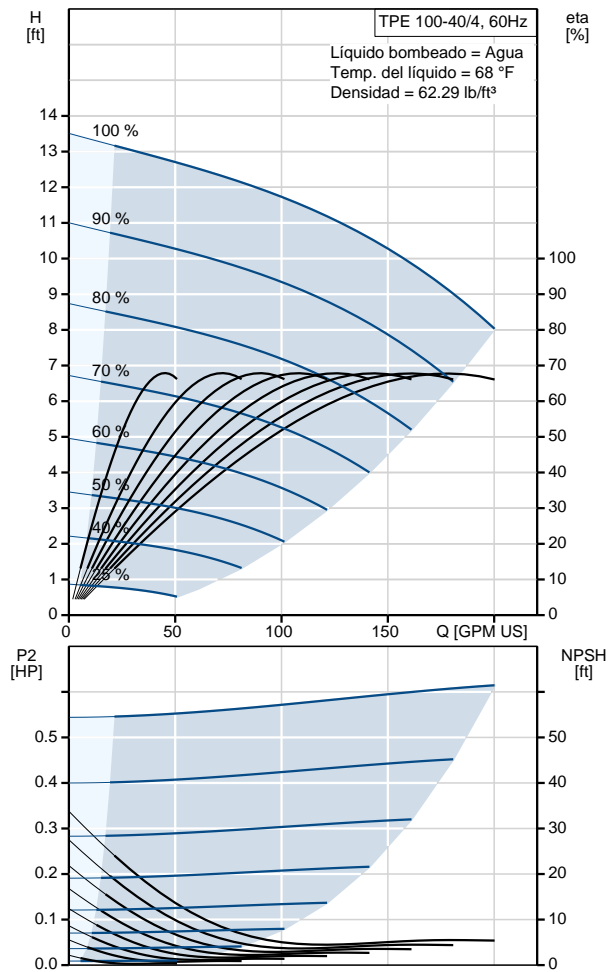

91136145 TPE 100-40/4 60 Hz

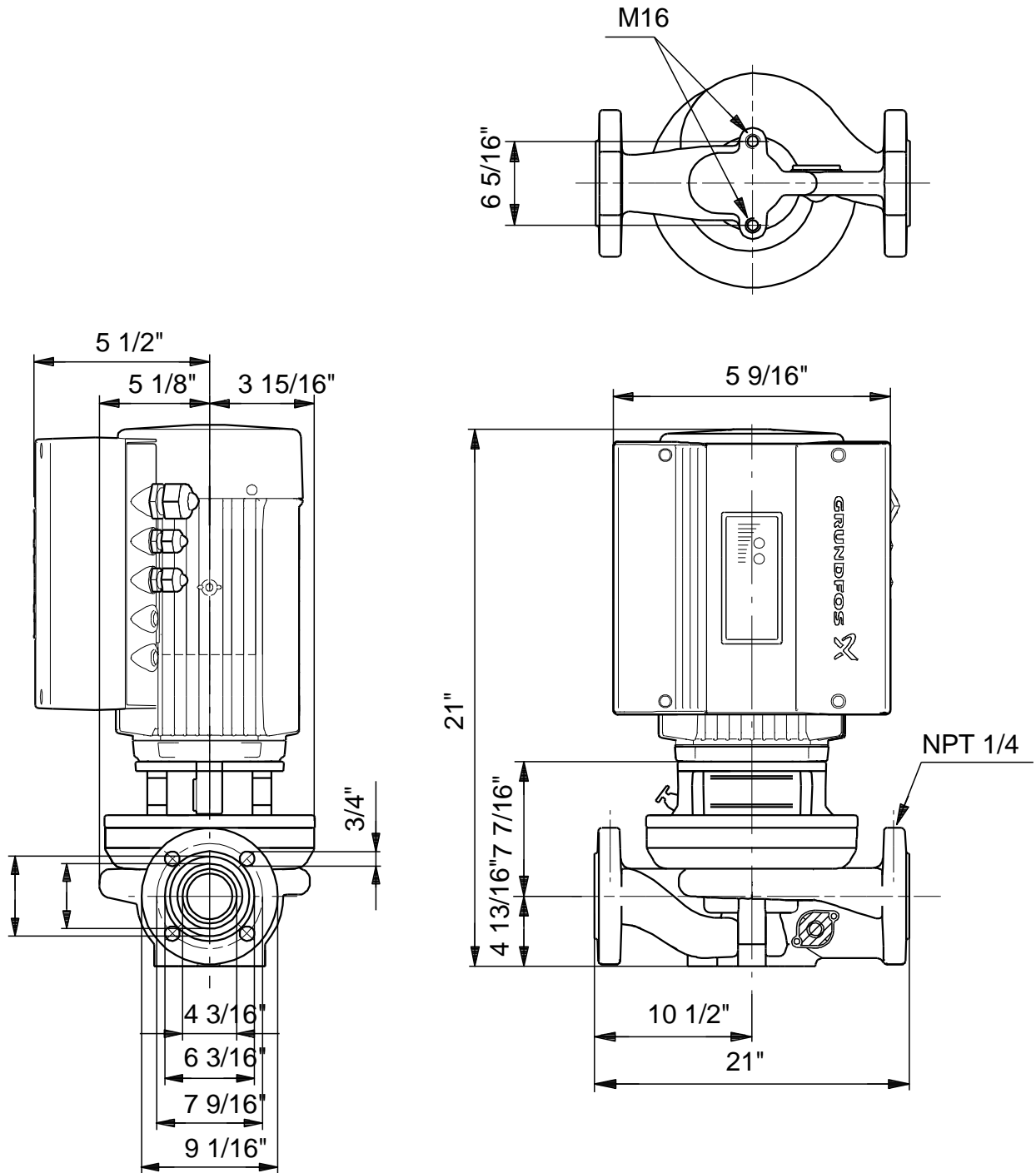

Nota: Todas las unidades están en [mm] a menos que se establezcan otras.