

18S SERIES - 1-1/2 HP

APPLICATIONS

Sewage and effluent wastewater transfer, dewatering

FEATURES

- Permanent Split Capacitor (PSC)
- Designed for continuous duty
- Capacitor and power cord connections are isolated from oil-filled motor housing for ease of field maintenance
- 3" FNPT (761 mm) discharge
- Handles solids up to 2" (51 mm) diameter
- 140 °F (60 °C) liquid temperature rating
- cCSAus listed



SERIES SPECIFICATIONS

Volts	Hz	Amps		Watts	Performance (GPM @ Height in Feet)					Shut-Off (ft)	PSI
		FLA	Start		10'	20'	30'	40'	50'		
200-208	60	16	31.0	3229	160	137	111	84	50	64	27.7
200-208*	60	13.5	32.0	1644	160	137	111	84	50	64	27.7
230	60	15.5	31.0	3512	160	137	111	84	50	64	27.7
230*	60	11.5	35.0	1512	160	137	111	84	50	64	27.7
460*	60	5.3	17.5	1474	160	137	111	84	50	64	27.7

* 3-phase

Item No.	Model	HP	Volts	Phase	Switch Type/ Operation	Cord	Weight
520300	18S-CIM	1-1/2	208	1	Manual	20' 6.1 m	94 lbs 42.64 Kg
520302	18S-CIM	1-1/2	200-208	3**	Manual	20' 6.1 m	96 lbs 43.54 Kg
520301	18S-CIM	1-1/2	230	1	Manual	20' 6.1 m	96 lbs 43.54 Kg
520303	18S-CIM	1-1/2	230	3**	Manual	20' 6.1 m	94 lbs 42.64 Kg
520304	18S-CIM	1-1/2	460	3**	Manual	40' 12 m	94 lbs 42.64 Kg

** Three-phase pumps must have a three-phase control panel for automatic or manual operation

SEWAGE PUMPS

18S SERIES - 1-1/2 HP

ENGINEERING DATA

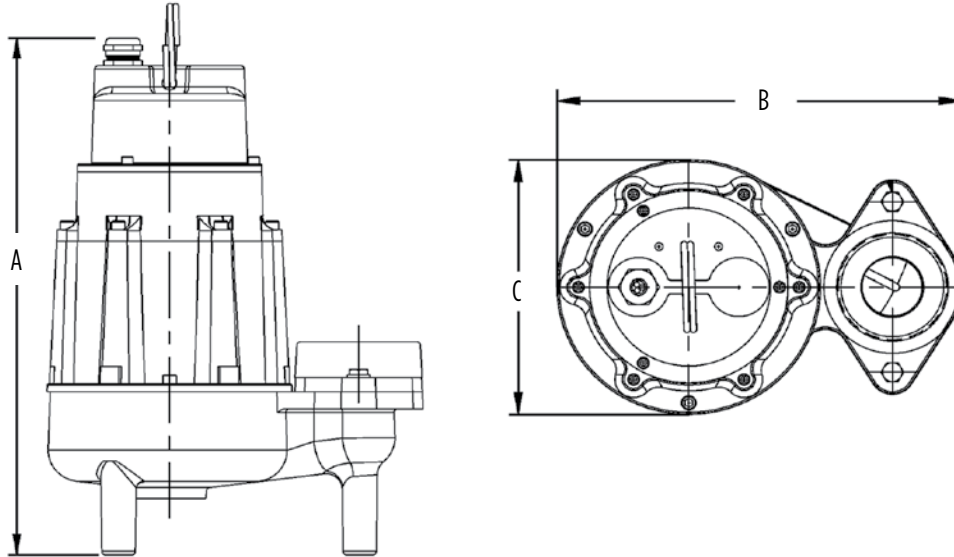

A	B	C
18.4"	13"	8.4"
46.74 cm	33.02 cm	21.34 cm

PERFORMANCE DATA

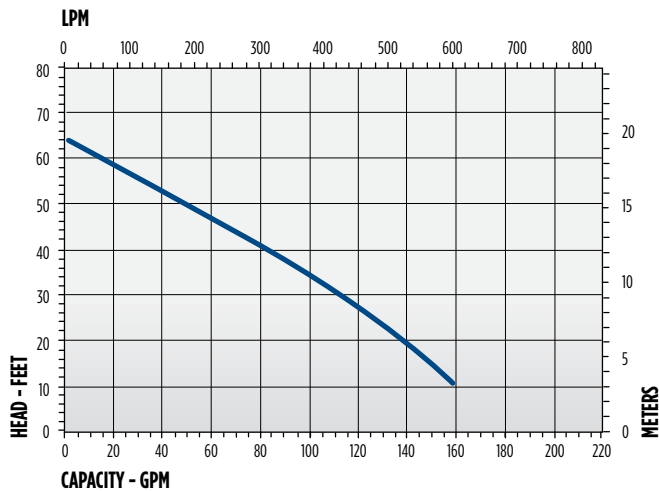

CONSTRUCTION

Cover	Epoxy-coated cast iron
Motor Housing	Epoxy-coated cast iron
Impeller Material	Red brass
Impeller Type	Non-clog vortex
Volute	Epoxy-coated cast iron
Mechanical Shaft Seal	Carbon/ceramic
Fasteners	Stainless steel
Shaft	Stainless steel
Bearings	Upper and lower ball bearings
Power Cord	14/3, SOW (1-phase); 14/4, SOW (3-phase)