

20E SERIES - 2 HP

APPLICATIONS

Effluent wastewater removal, dewatering, water transfer

FEATURES

- Permanent Split Capacitor (PSC)
- Completely submersible, designed for continuous duty
- 2" NPT (51 mm) discharge
- Handles solids up to 3/4" (19 mm) diameter
- 140 °F (60 °C) liquid temperature rating
- cCSAus listed



SERIES SPECIFICATIONS

| Volts | Hz | Amps | | Watts | Performance (GPM @ Height in Feet) | | | | | Shut-Off (ft) | PSI |
|-----------|----|-------|-------|-------|------------------------------------|-----|-----|-----|-----|---------------|------|
| | | FLA | Start | | 20' | 30' | 40' | 60' | 80' | | |
| 230* | 60 | 16.4 | 31 | 3872 | 135 | 125 | 110 | 89 | 62 | 110 | 47.6 |
| 460** | 60 | 5.75 | 7.5 | 2571 | 135 | 125 | 110 | 89 | 62 | 110 | 47.6 |
| 200-208** | 60 | 13.1 | 32 | 2478 | 135 | 125 | 110 | 89 | 62 | 110 | 47.6 |
| 230** | 60 | 11.64 | 28.3 | 2476 | 135 | 125 | 110 | 89 | 62 | 110 | 47.6 |

| Item No. | Model | HP | Volts | Phase | Cord | Weight |
|----------|---------|----|---------|-------|--------------|----------------------|
| 520200 | 20E-CIM | 2 | 230 | 1* | 20' 6.1 m | 92 lbs 41.47 Kg |
| 520230 | 20E-CIM | 2 | 230 | 1* | 30' 9.1 m | 93.5 lbs 42.41 Kg |
| 520250 | 20E-CIM | 2 | 230 | 3** | 20' 6.1 m | 92 lbs 41.47 Kg |
| 520275 | 20E-CIM | 2 | 460 | 3** | 20' 6.1 m | 92 lbs 41.47 Kg |
| 520225 | 20E-CIM | 2 | 200-208 | 3** | 20' 6.1 m | 92 lbs 41.47 Kg |

* Single-phase pumps can use a mechanical float switch or a single-phase control panel for automatic on/off

** Three-phase pumps must have a three-phase control panel for automatic or manual operation

EFFLUENT PUMPS

20E SERIES - 2 HP

ENGINEERING DATA

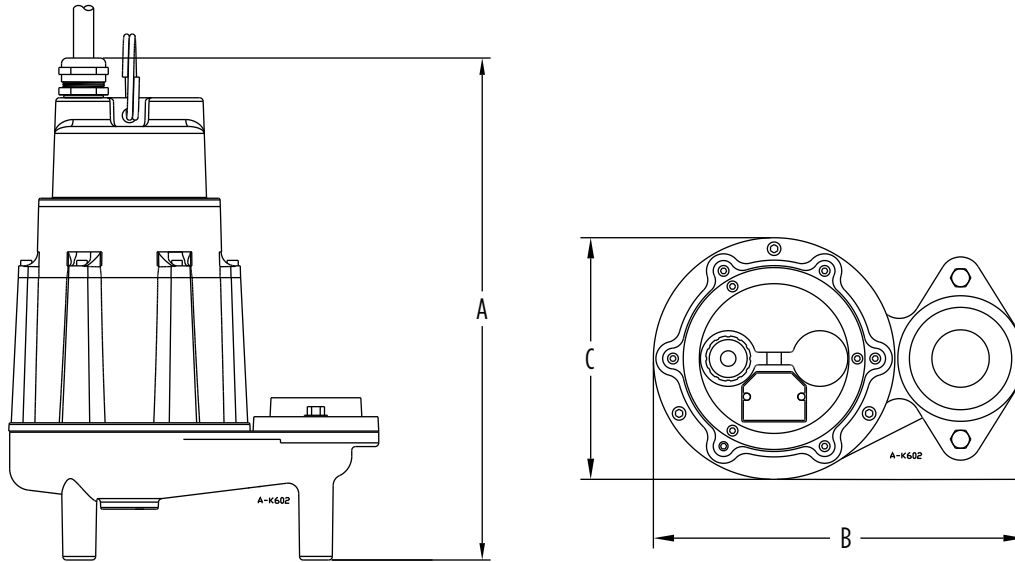

| A | B | C |
|--------------------|--------------------|-------------------|
| 17.75" 45.09 cm | 12.93" 32.84 cm | 8.42" 21.39 cm |

PERFORMANCE DATA

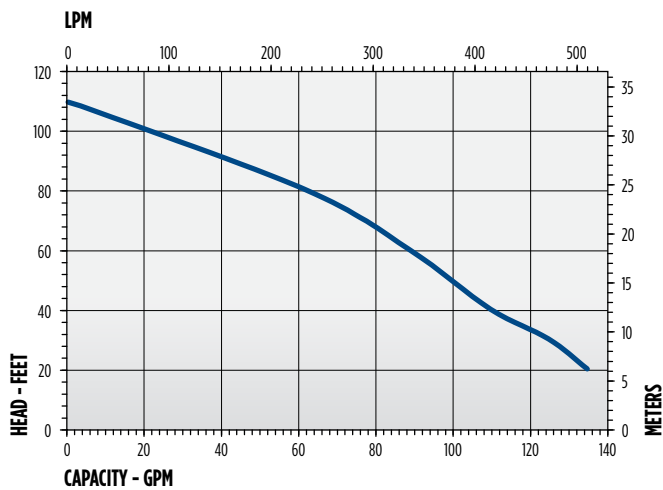

CONSTRUCTION

| | |
|------------------------------|-------------------------------|
| Cover | Epoxy-coated cast iron |
| Motor Housing | Epoxy-coated cast iron |
| Impeller Material | Red brass |
| Impeller Type | Vortex |
| Volute | Epoxy-coated cast iron |
| Mechanical Shaft Seal | Carbon/ceramic |
| Fasteners | Stainless steel |
| Shaft | Stainless steel |
| Bearings | Upper and lower ball bearings |
| Power Cord | SOOW |