

# Data Sheet

## Series C

### Electronic Metering Pumps

### Configuration Data

Model **C92** **1** - **363SI**

#### Control & Output Code

##### Manual Control

Speed (stroking frequency) and stroke length manually adjustable.

C10 --- 1.3 GPH (4.9 l/h) ... 300 psi (20.7 Bar)  
 C11 --- 2.5 GPH (9.5 l/h) ... 150 psi (10.3 Bar)  
 C12 --- 4.0 GPH (15.1 l/h) ... 100 psi (6.9 Bar)  
 C13 --- 8.0 GPH (30 l/h) ..... 60psi (4.1 Bar)  
 C14 ---- 20 GPH (76 l/h) ..... 25 psi (1.7 Bar)

##### Instrument Responsive/Manual Control

Manual adjustment features of C1 Series plus switch conversion to external control for automatic systems.

C70 --- 1.3 GPH (4.9 l/h) ... 300 psi (20.7 Bar)  
 C71 --- 2.5 GPH (9.5 l/h) ... 150 psi (10.3 Bar)  
 C72 --- 4.0 GPH (15.1 l/h) ... 100 psi (6.9 Bar)  
 C73 --- 8.0 GPH (30 l/h) ..... 60 psi (4.1 Bar)  
 C74 ---- 20 GPH (76 l/h) ..... 25 psi (1.7 Bar)  
 C76\* -- 4.0 GPH (15.1 l/h) ... 175 psi (12.1 Bar)  
 C77\* --- 10 GPH (38 l/h) ..... 80 psi (5.5 Bar)  
 C78\* --- 25 GPH (95 l/h) ..... 30 psi (2.07 Bar)  
 C90 --- 1.3 GPH (4.9 l/h) ... 300 psi (20.7 Bar)  
 C91 --- 2.5 GPH (9.5 l/h) ... 150 psi (10.3 Bar)  
 C92 --- 4.0 GPH (15.1 l/h) ... 100 psi (6.9 Bar)  
 C93 --- 8.0 GPH (30 l/h) ..... 60 psi (4.1 Bar)  
 C94 ---- 20 GPH (76 l/h) ..... 25 psi (1.7 Bar)

#### Voltage Code

1 ----- 120 VAC US Plug  
 2 ----- 240 VAC US Plug  
 3 ----- 220-240 VAC DIN Plug  
 5 ----- 240-250 VAC, UK Plug  
 6 ----- 240-250 VAC, AUST/NZ Plug  
 7 ----- 220-240 VAC, SWISS Plug

#### Liquid End

See next page for complete liquid end specifications and selection.

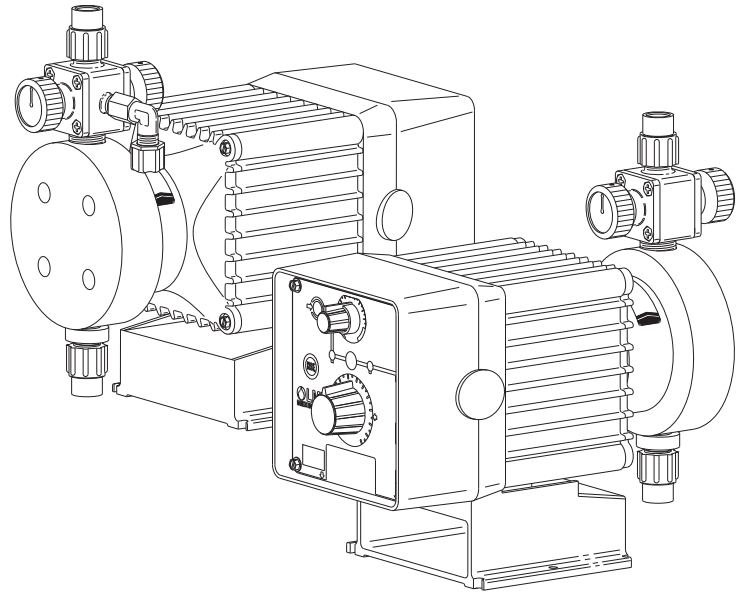

### Dimensions

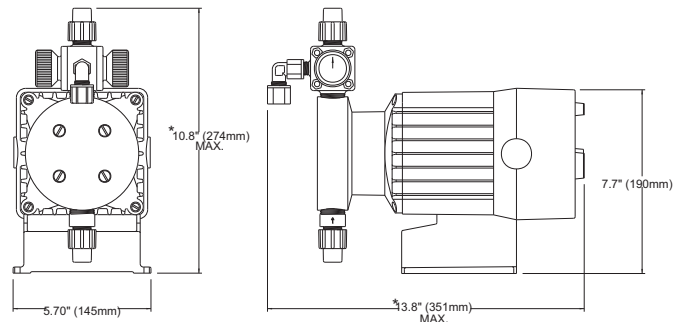

\*DIMENSIONS SHOWN ARE MAXIMUM FOR LARGEST LIQUID END AVAILABLE. THESE DIMENSIONS VARY DEPENDING ON THE LIQUID END SELECTED.

### Specifications

Series	Strokes Per Minute (Adjustable)		Stroke Length (Adjustable) Minimum	Average Input Power @Max Speed	Shipping Weight
	Min	Max			
C10, C70, C90 C11, C71, C91 C12, C72, C92 C13, C73, C93 C14, C74, C94	1	100	10%	44 watts	20 lbs (9.1 kg)
C76 C77 C78	1	100	10%	87watts	28 lbs (12.7 kg)

## Standard Liquid End Configuration Data & Materials of Construction

Drive Assembly	Liquid End No.	Size Code	Materials of Construction				Accessory	Tubing & Connections	
			Head & Fittings	Balls	Liquifram™	Check Valve		Discharge	Suction
C90, C70 - C10 -	498SP	0.9	PVC	Ceramic	Fluorofilm™	PVDF / PTFE	4FV	Pipe 1/2" NPT M	
	297	0.9	316 S.S.	316 S.S.	Fluorofilm™	316 S.S.		Pipe 1/4" NPT M	
C92 - C91 - C72 - C71 - C12 - C11 -	468SI	1.8	PVC / PVC	Ceramic	Fluorofilm™	PVDF / Polyprel®	4FV	PE .375" O.D.	
	460SI	1.8	Acrylic / PVC	Ceramic	Fluorofilm™	PVDF / Polyprel®	4FV	PE .375" O.D.	
	469SI	1.8	Acrylic / PVDF	PTFE	Fluorofilm™	PVDF / Polyprel®	4FV	PE .375" O.D.	
	368SI†	1.8	PVC / PVC	Ceramic	Fluorofilm™	PVDF / Polyprel®	4FV	PE .375" O.D.	
	362SI†	1.8	PVDF / PVDF	Ceramic	Fluorofilm™	PVDF / Polyprel®	4FV	PE .375" O.D.	
	363SI†	1.8	PVDF / PVDF	Ceramic	Fluorofilm™	PVDF / PTFE	4FV	PE .375" O.D.	
	465SI	1.8	Polypropylene	Ceramic	Fluorofilm™	PVDF / PTFE	4FV	PE .375" O.D.	
	75HV	1.8	Polypropylene	316 S.S.	Fluorofilm™	PTFE		PE .5" O.D. Vinyl .938" O.D.	
	76HV	1.8	Acrylic/PP	316 S.S.	Fluorofilm™	Hypalon®		PE .5" O.D. Vinyl .938" O.D.	
	277	1.8	316 S.S.	316 S.S.	Fluorofilm™	316 S.S.		Pipe 1/4" NPT M	
C93 - C73 - C13 -	312SI#	3.0	PVDF / PVDF	Ceramic	Fluorofilm™	PVDF / Polyprel®	4FV	PE .5" O.D.	
	313SI#	3.0	PVDF / PVDF	Ceramic	Fluorofilm™	PVDF / PTFE	4FV	PE .5" O.D.	
	318SI#	3.0	PVC / PVC	Ceramic	Fluorofilm™	PVDF / Polyprel®	4FV	PE .5" O.D.	
	410SI#	3.0	Acrylic / PVC	Ceramic	Fluorofilm™	PVDF / Polyprel®	4FV	PE .5" O.D.	
	415SI#	3.0	Polypropylene	Ceramic	Fluorofilm™	PVDF / PTFE	4FV	PE .5" O.D.	
	418SI#	3.0	PVC / PVC	Ceramic	Fluorofilm™	PVDF / Polyprel®	4FV	PE .5" O.D.	
	419SI#	3.0	Acrylic / PVDF	PTFE	Fluorofilm™	PVDF / Polyprel®	4FV	PE .5" O.D.	
	20	3.0	Acrylic / PVC	Ceramic	Fluorofilm™	Hypalon®		PE .5" O.D.	
	20HV	3.0	Acrylic/PP	316 S.S.	Fluorofilm™	Hypalon®		PE .5" O.D. Vinyl .938" O.D.	
	20S	3.0	Acrylic/PVC	Ceramic	Fluorofilm™	Hypalon®	4FV	PE .5" O.D. Vinyl .5" O.D.	
	24	3.0	PVC	Ceramic	Fluorofilm™	PTFE		Pipe 1/2" NPT M	
	25HV	3.0	Polypropylene	316 S.S.	Fluorofilm™	PTFE		PE .5" O.D. Vinyl .938" O.D.	
	26	3.0	PVC	Ceramic	Fluorofilm™	Viton®		PE .5" O.D.	
	26S	3.0	PVC	Ceramic	Fluorofilm™	Viton®	4FV	PE .5" O.D.	
	27	3.0	316 S.S.	316 S.S.	Fluorofilm™	PTFE		Pipe 1/2" NPT M	
	29	3.0	UHMW PE	Ceramic	Fluorofilm™	Hypalon®		PE .5" O.D.	
	C94 - C78 - C74 - C14 -	30	6.0	Acrylic/PVC	Ceramic	Fluorofilm™	PTFE		PE .5" O.D. Vinyl .5" O.D.
34		6.0	PVC	Ceramic	Fluorofilm™	PTFE		Pipe 1/2" NPT M	
35P		6.0	Polypropylene	Ceramic	Fluorofilm™	PTFE		Pipe 1/2" NPT M	
35T		6.0	Polypropylene	Ceramic	Fluorofilm™	PTFE		PE .5" O.D.	
36		6.0	PVC	Ceramic	Fluorofilm™	PTFE		PE .5" O.D.	
C76 -	468SP	1.8	PVC/PVC	Ceramic	Fluorofilm™	PVDF / Polyprel®	4FV	Pipe 1/2" NPT M	
	74S	1.8	PVC	Ceramic	Fluorofilm™	PTFE	4FV	Pipe 1/4" NPT M	
	277	1.8	316 S.S.	316 S.S.	Fluorofilm™	316 S.S.		Pipe 1/4" NPT M	
C77 -	20HV	3.0	Acrylic/PP	316 S.S.	Fluorofilm™	Hypalon®		PE .5" O.D. Vinyl .938" O.D.	
	20S**	3.0	Acrylic/PVC	Ceramic	Fluorofilm™	Hypalon®	4FV	PE .5" O.D. Vinyl .5" O.D.	
	24	3.0	PVC	Ceramic	Fluorofilm™	PTFE		Pipe 1/2" NPT M	
	25HV	3.0	Polypropylene	316 S.S.	Fluorofilm™	PTFE		PE .5" O.D. Vinyl .938" O.D.	
	25P	3.0	Polypropylene	Ceramic	Fluorofilm™	PTFE		Pipe 1/2" NPT M	
	25T	3.0	Polypropylene	Ceramic	Fluorofilm™	PTFE		PE .5" O.D.	
	26S**	3.0	PVC	Ceramic	Fluorofilm™	Viton®	4FV	PE .5" O.D.	
	27	3.0	316 S.S.	316 S.S.	Fluorofilm™	PTFE		Pipe 1/2" NPT M	
29	3.0	UHMW PE	Ceramic	Fluorofilm™	Hypalon®		PE .5" O.D.		

## Output Information

Series	Gallons per Hour		Liters per Hour		mL/cc per Minute		mL/cc per Stroke		Maximum Injection Pressure	
	Min	Max	Min	Max	Min	Max	Min	Max		
C10, C70*, C90*	0.001	1.3	0.005	4.9	0.08	82	0.08	0.82	300 psi	(20.7 Bar)
C11, C71*, C91*	0.003	2.5	0.010	9.5	0.16	158	0.16	1.58	150 psi	(10.3 Bar)
C12, C72*, C92*	0.004	4.0	0.015	15.1	0.25	252	0.25	2.52	100 psi	(6.9 Bar)
C13, C73*, C93*	0.008	8.0	0.030	30.0	0.51	505	0.51	5.05	60 psi	(4.1 Bar)
C14, C74*, C94*	0.020	20.0	0.076	76.0	1.26	1262	1.26	12.62	25 psi	(1.7 Bar)
C76*	0.004	4.0	0.015	15.1	0.25	252	0.25	2.52	175 psi	(12.1 Bar)
C77*	0.010	10.0	0.038	38.0	0.63	631	0.63	6.31	80 psi	(5.5 Bar)
C78*	0.025	25.0	0.095	95.0	1.58	1577	1.58	15.77	30 psi	(2.07 Bar)

\* Minimum output is based on 1 stroke per minute and 10% stroke setting, minimum output can be reduced further in external mode. Series C9 pumps may be programmed for strokes per hour for lower outputs.

## AutoPrime Liquid End Configuration Data & Materials of Construction

Drive Assembly	Liquid End No.	Size Code	Head & Fittings	Balls	Liquifram™	Check Valve	Accessory	Tubing & Connections
C11 C71 C91	D60HI	1.8	Acrylic / PVC	Ceramic	Fluorofilm™	PVDF / Polyprel®	4FV	PE .375" O.D.
C12 C72 C92	D68HI	1.8	PVC / PVC	Ceramic	Fluorofilm™	PVDF / Polyprel®	4FV	PE .375" O.D.

## Output Information - AutoPrime Liquid Ends (Liquid end models beginning with "D")

Series	Maximum Output			Maximum Pressure		
	GPH	Liters/hr	mL/cc per minute	mL/cc per stroke	PSI	Bar
C11, C71, C91	2	7.5	125.0	1.25	150 psi	10.3
C12, C72, C92	2.5	9.5	158.3	1.58	100 psi	6.9

Auto prime liquid ends have 3 check valves: Suction on the bottom; Discharge on the front; AutoPrime bleed on the top. By design, a repeatable portion of the process fluid continuously bleeds through the top check valve to be returned to the chemical supply. The result is the assurance that any gas in the head is automatically relieved thus eliminating air-binding. The maximum output per the tables above is reduced to account for the continuous bleed.

See front page for voltage code specifications.

Plastic heads with tubing connection include 1/2" NPT and 1/2" BSP.

\*\*These Liquid Ends are available without a 4FV, simply drop the 'S' at the end of the Liquid End number to order the model without a 4FV.

#These liquid ends use 3/8" diameter balls. Pump output may be reduced in some applications.

To specify 1/4" NPT male, change 'I' to 'P'.

To specify black, UV resistant tubing, change "I" to "U".

To specify 3FV, change "S" to "T".

**3FV** indicates that the pump is equipped with an LMI Three Function Valve (pressure relief, priming aid, line drain).

**4FV** indicates that the pump is equipped with an LMI Four Function Valve. This diaphragm type, anti-siphon/pressure relief valve is installed on the pump head. It provides

Fluorofilm™ is a copolymer of PTFE and PFA. Polyprel® is an elastomeric PTFE copolymer.

Polyprel is a registered trademark of the Milton Roy Company.

Fluorofilm and Liquifram are trademarks of the Milton Roy Company.

Hypalon is a registered trademark of E. I. du Pont de Nemours & Co., Inc.