



Equipos  
de Bombeo

®

Barmesa

CURVA DE RENDIMIENTO  
BOMBA CENTRIFUGA TIPO CARACOL

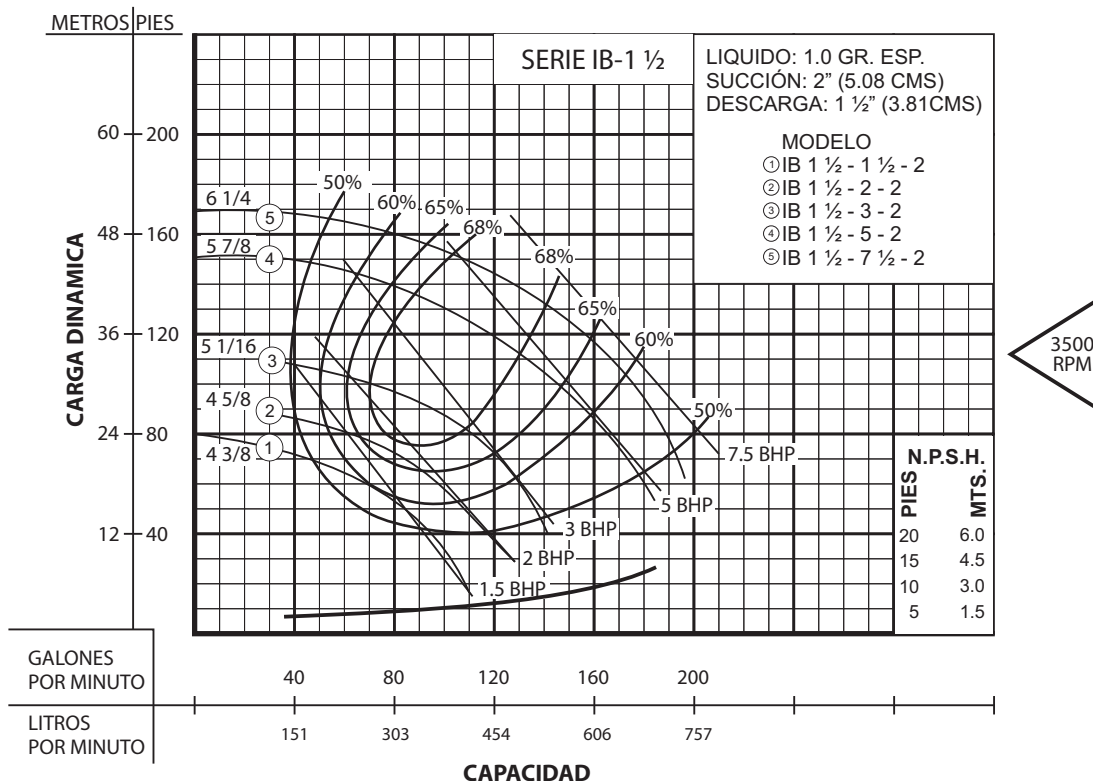
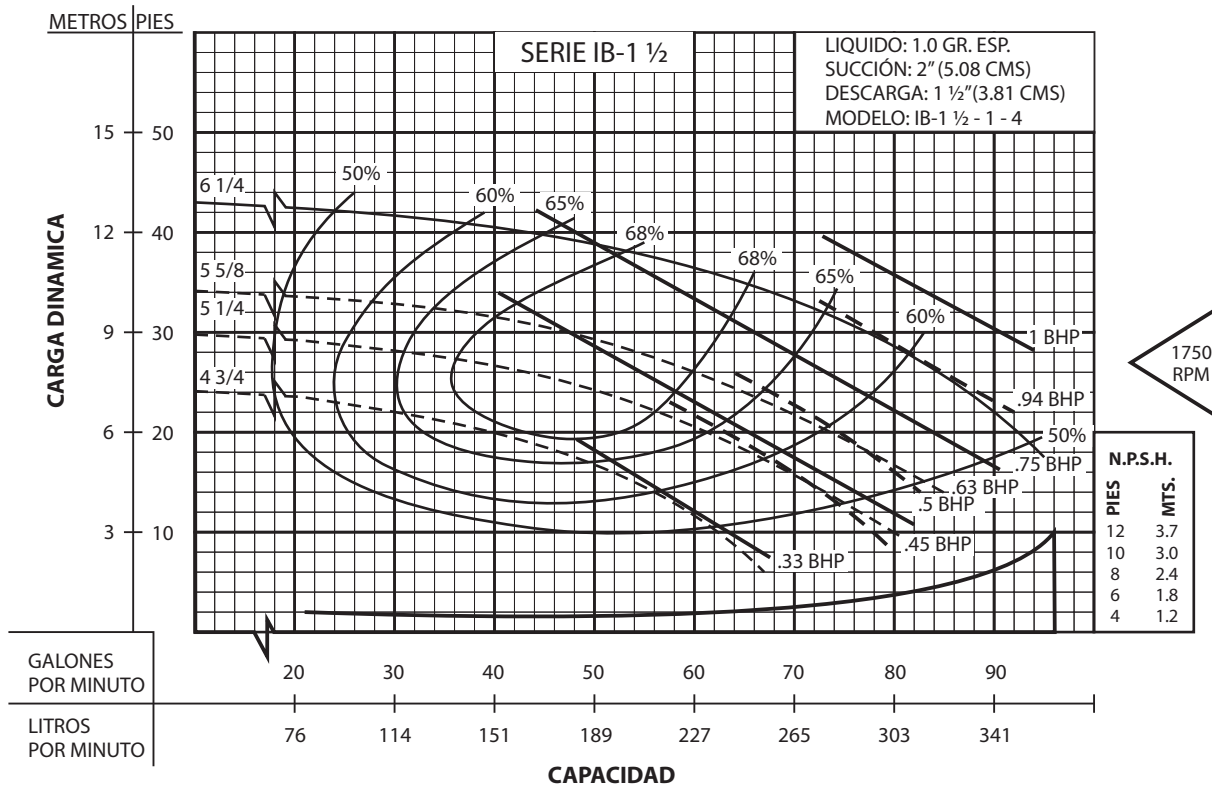

GPM= Galones por minuto  
LPM= Litros por minuto

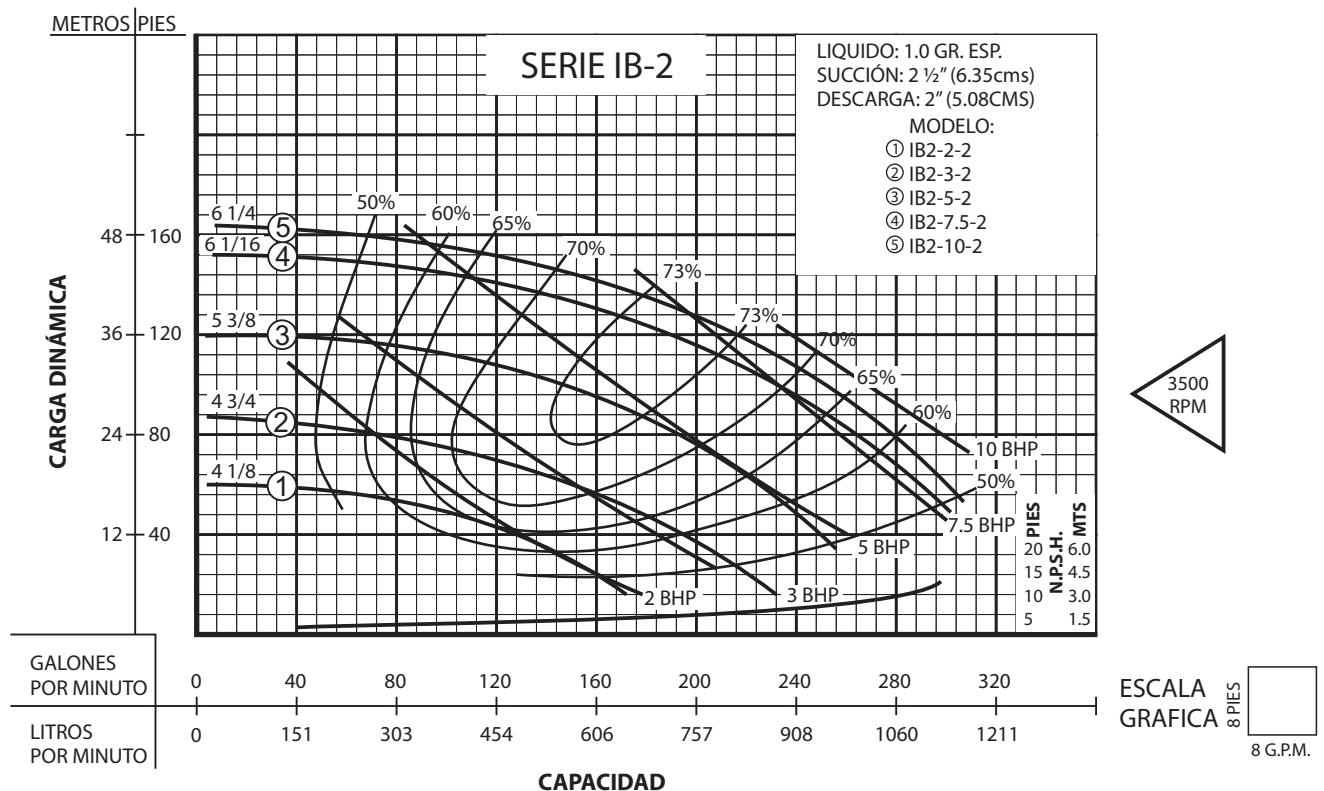
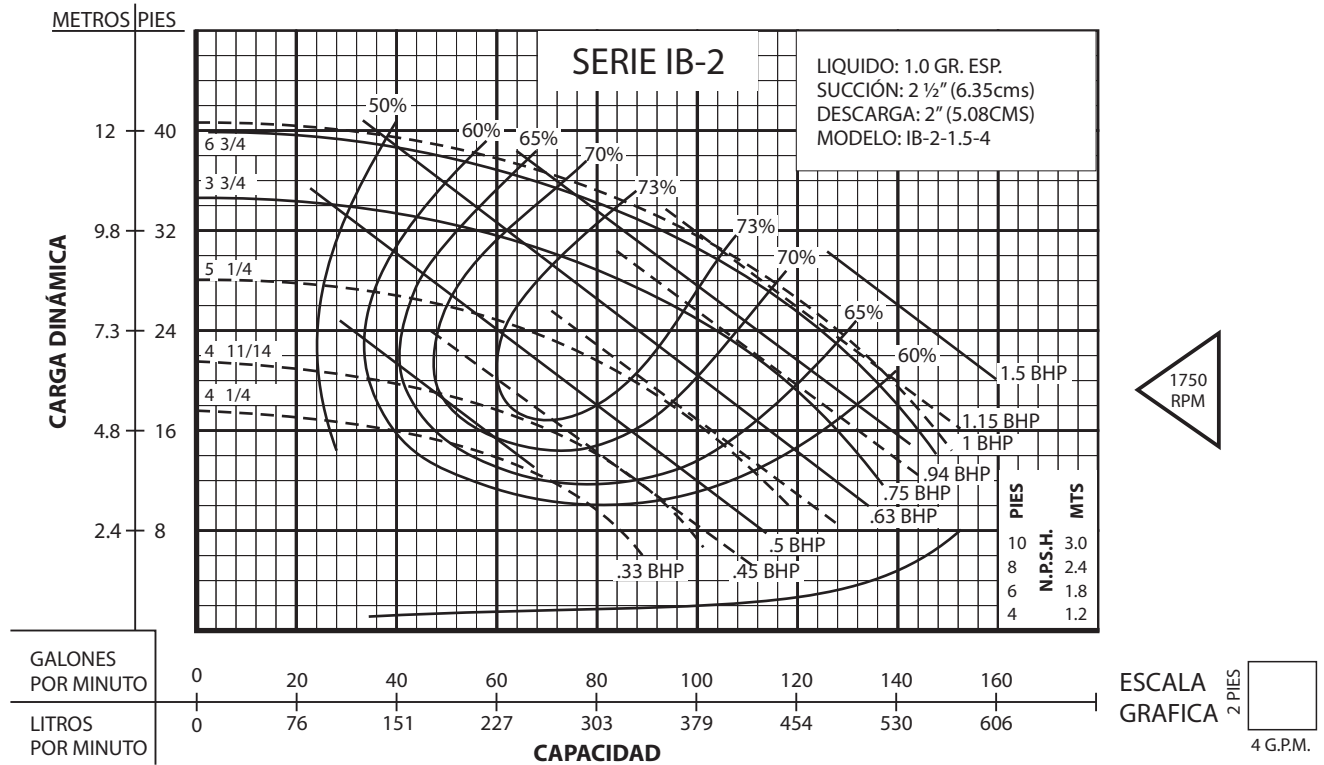



Equipos  
de Bombeo

®

Barmesa

CURVA DE RENDIMIENTO  
BOMBA CENTRIFUGA TIPO CARACOL

