

Little GIANT®

4E-34N SERIES



Features

- Epoxy coated die-cast aluminum housing
- Oil-filled motor
- 23.1' maximum lift
- 210 watts
- 1/2" MNPT discharge
- Thermal overload protection
- For submersible use only

Construction

- Motor — 1/12 HP oil filled heavy duty
- Intermittent Liquid Temp — 120°F
- Intake — 3/4" FNPT
- Discharge — 1/2" MNPT
- Housing — Epoxy coated cast aluminum
- Cover — Epoxy coated cast aluminum
- Volute — Nylon
- Impeller — Nylon
- Shaft Seal — Viton®
- Screen — Polypropylene



Small submersible oil-filled pump with epoxy coated cast aluminum housing. For commercial, industrial and home applications including statuary fountains, water displays, air conditioners, machine tool coolants, and many other applications where liquid must be transferred or recirculated. This compact 710 GPH pump features a 1/2" MNPT discharge, 23.1' shut-off head capability, and screened inlet.

4E-34N SERIES

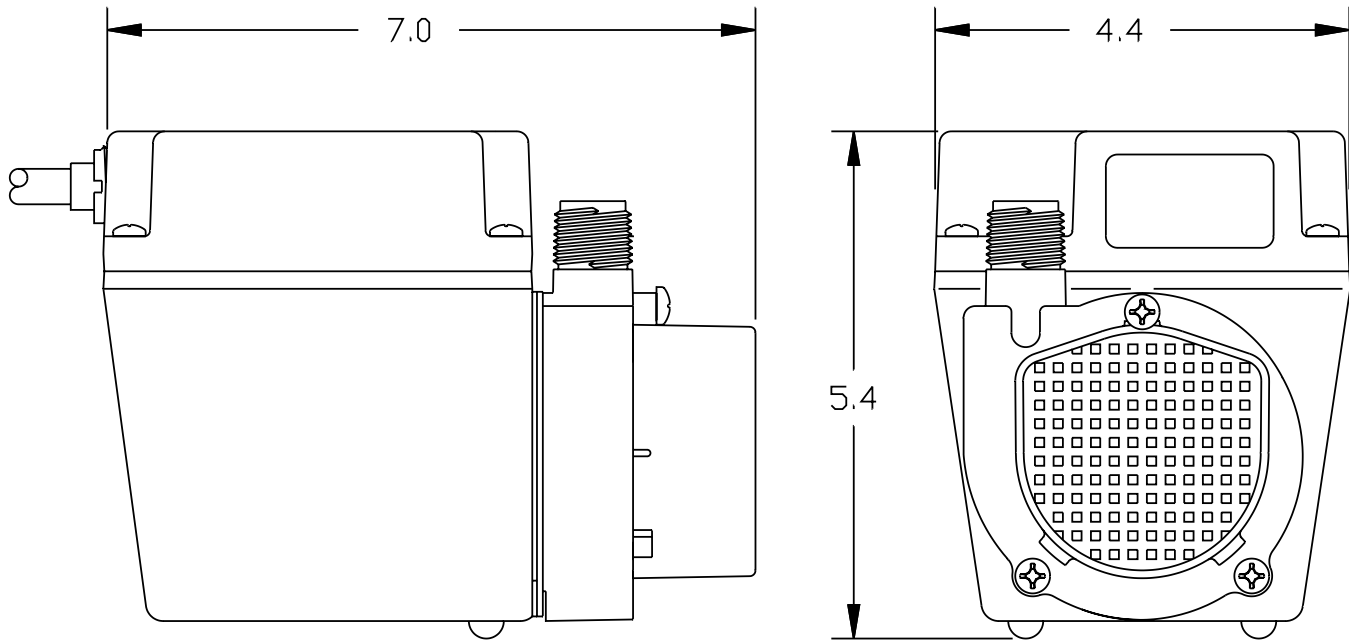

Specifications

Model No.	Item No.	Discharge Size	Listing(s)	HP	Volts	Hertz	Amps	Watts	Performance (GPH@Head)					Shutoff		Cord Length (ft.)	Weight (lbs.)
									1'	3'	5'	10'	20'	Ft.	P.S.I.		
4E-34N	504103	1/2" MNPT	UL	1/12	115	60	3.5	210	710	690	670	580	150	23.1	10.0	6	8.50
4E-34NT	504186	1/2" MNPT	UL/CSA	1/12	115	60	3.5	210	710	690	670	580	150	23.1	10.0	10	8.50

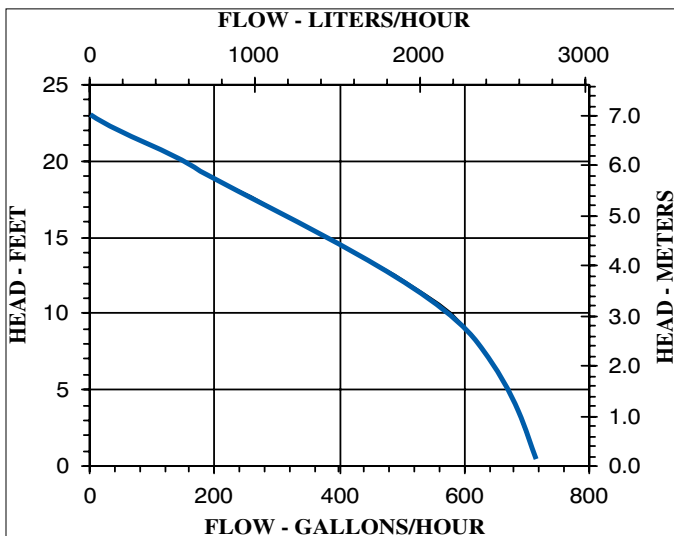

Replacement Parts

Volute	103334
Screen	102909
Impeller	104435
Gasket	103601