

S range 1.65 – 5.0 kW

50 and 60 Hz versions

GRUNDFOS 



Powerful pumps for handling unscreened raw sewage

Grundfos offers a complete range of highly dependable, powerful sewage pumps, designed for handling unscreened raw sewage. With more than forty years' experience in providing specialised pumps and pumping equipment for all kinds of wastewater and sewage, we know better than anyone what our customers demand from a wastewater pump.



➤ High pump efficiency over time

Advanced technology makes the Grundfos pumps extremely efficient and highly dependable. Innovative features such as SmartTrim adjustment of the impeller clearance ensure long-term high pump efficiency and low life-cycle costs.

➤ Less down time

The inherent non-clogging design of our SuperVortex impeller pumps and the excellent solids handling capability of our channel impeller pumps guarantee maximum up time and substantial reduction in service costs caused by pump jamming or clogging.

➤ Life-long reliability

The Grundfos wastewater pumps are of a well-proven design that ensures life-long reliability even under the most difficult operation conditions.

At Grundfos we strive to maintain a close dialogue with our customers in order to constantly improve our pump designs and performance. Only this way are we able to build the long-lasting relationships on which our business is founded.



Installation options

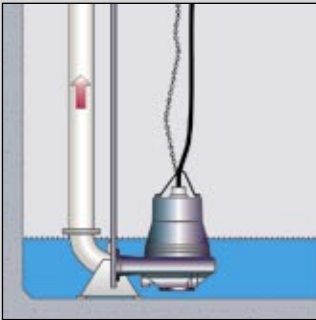

Submerged installation on auto-coupling, types S and C

Submerged installation on auto-coupling system requires a base plate with a 90° bend, fixed to the bottom of the pit. When lowered into the pit along the guide rails, the pump automatically connects to the base plate. The flexible neoprene SmartSeal ensures a leak-proof connection between the pump and the auto-coupling.

Type S:

To prevent sedimentation of sludge at intermittent operation, we recommend a stop level corresponding to the top of the pump housing. For sufficient cooling at continuous operation, the liquid level must be kept above mid-motor level at all times.

Type C:

Motor cooling is independent of the pumped liquid level.

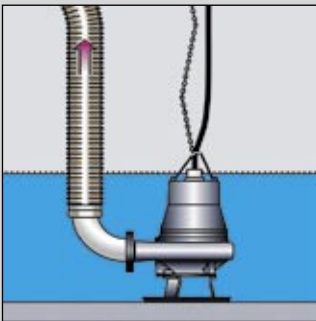

Submerged installation, portable, types S and C

Certain applications, such as construction sites, require portable submersibles. Where a portable submersible is required, hoses of varying lengths and materials can be supplied.

Type S:

To prevent sedimentation of sludge at intermittent operation, we recommend a stop level corresponding to the top of the pump housing. For sufficient cooling at continuous operation, the liquid level must be kept above mid-motor level at all times.

Type C:

Motor cooling is independent of the pumped liquid level.

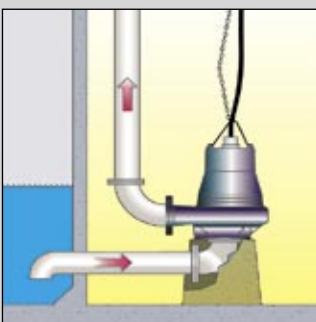

Vertical dry installation, type D

The Grundfos sewage pumps can be installed vertically or horizontally to suit specific application arrangements. The pumps are 100% watertight, allowing for dry installation with the workspace around the pump remaining clean and dry. If an unexpected flooding should occur, the Grundfos pumps are fully flood-proof.

Motor cooling is effected by internal cooling of the pump.

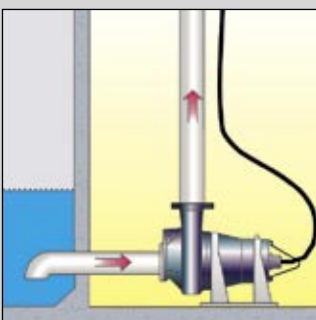

Horizontal dry installation, type D

Horizontal dry installation improves the overall efficiency of the pumping system as unnecessary components and bends are avoided. As the system takes up slightly more space than a vertically installed pump, the feasibility of horizontal dry installation depends on the floor space available.

Motor cooling is effected by internal cooling of the pump.

Grundfos SuperVortex impellers

A unique impeller design

The unique design of the Grundfos SuperVortex impellers provides high pumping efficiency and less downtime. With a flow range from 4 l/s, the Grundfos SuperVortex-impeller pumps are the optimum solution for all small pumping stations.

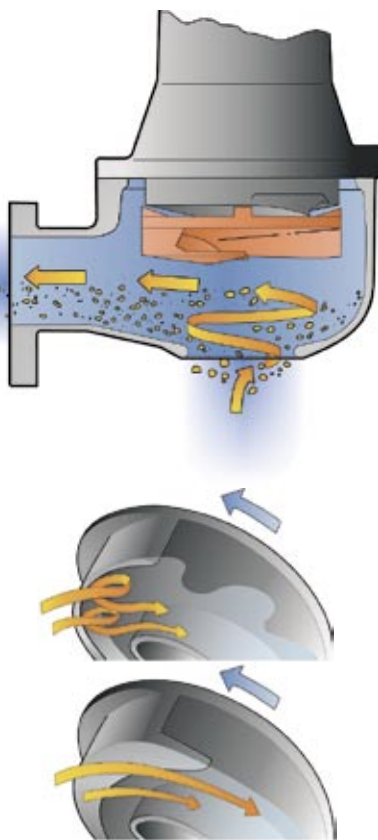

No clogging or jamming

In a SuperVortex-impeller pump, the flow is entirely outside the impeller. The design of the impeller ensures that long fibres, rags, etc. pass freely through the pumps without getting caught and without causing clogging or jamming. This means less downtime and, consequently, reduced service costs and higher pumping efficiency.

The design of the SuperVortex-impeller pumps also prevents the common problem of jamming between wear rings. A Grundfos SuperVortex-impeller pump needs no wear rings!

Conventional vortex impeller

In pumps fitted with a conventional vortex impeller, turbulent disturbance is liable to form around the impeller. This will disrupt the flow pattern and result in lower pumping efficiency and reduced head.

Grundfos SuperVortex impeller

The liquid passes freely outside the impeller without any turbulent disturbance.

Full performance curve without operating limitations and vibrations

Due to the special power characteristics of the Grundfos SuperVortex-impeller pumps, it is possible to run the pumps right up to the maximum flow on the curves without any risk of overloading the motor. The steep performance curve means minimal flow fluctuation with varying heads.

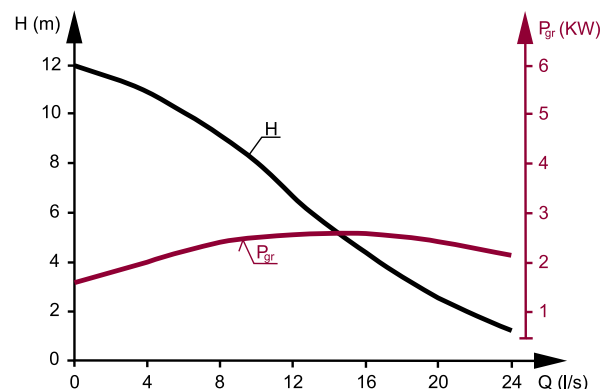

Grundfos channel impellers

Large free passage for superior solids handling

Compromising on the ability to handle solids in order to obtain higher pumping efficiency substantially increases the risk of clogging. More clogging means more downtime and increased operating costs. The Grundfos channel-impeller pumps provide high efficiency and excellent non-clogging capabilities. The channel impellers are designed with a large free passage \varnothing 80 mm.

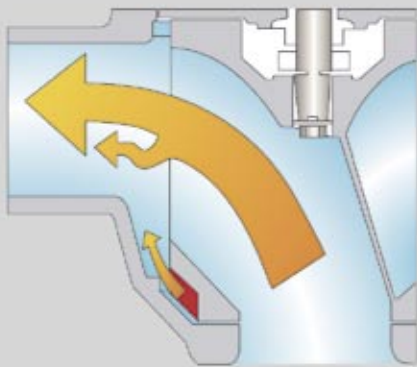
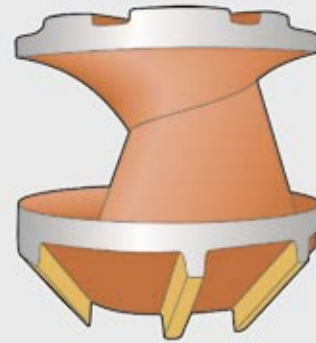

Self-cleaning impeller

On Grundfos wastewater pumps smaller than 12 kW, the bottom part of the channel impellers feature specially designed auxiliary vanes. These vanes are designed to create a powerful flow that keeps the clearance between the impeller and the pump housing free from solids or fibres.

Semi-axial impeller design with long vane

The length of an impeller vane is a key factor in determining the length of fibres that can pass through a pump without getting caught. The Grundfos channel impellers are of a semi-axial design with extra long vanes. This provides maximum performance and eliminates problems with fibres or rags getting caught in the impeller.

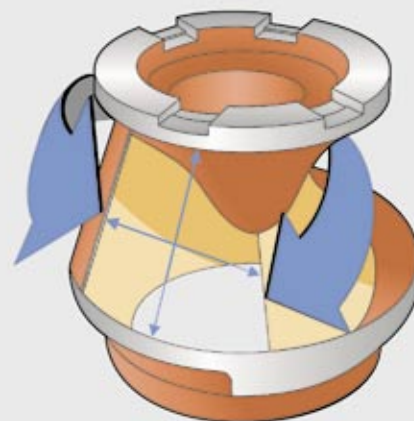

Performance overview and general data

Performance overview

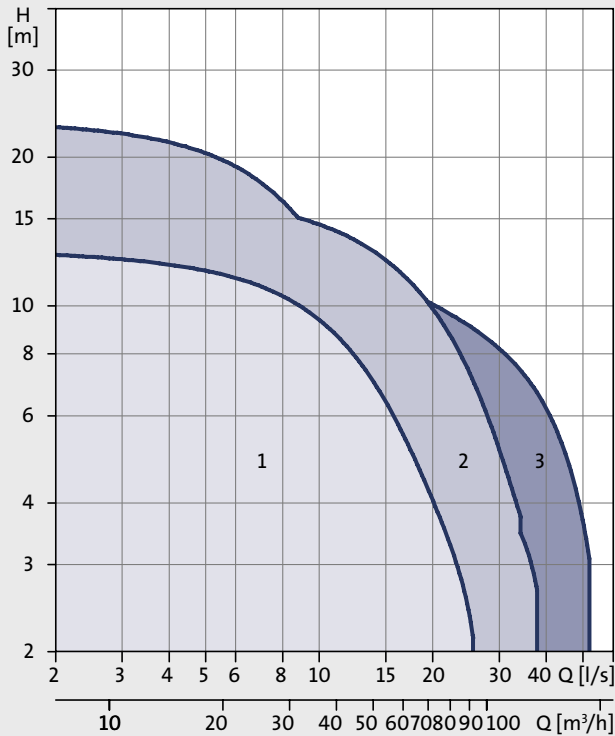

- ① SuperVortex impeller
ranges 34 – 42
- ② SuperVortex impeller
range 42
- ③ Channel impeller
range 42

Operating conditions and maximum starting frequency

Pump application is restricted by the following limits:

- Maximum ambient temperature and pumped liquid temperature: +40°C
- Storage temperature range: –30°C to +60°C
- Maximum installation depth: 20 m
- Voltage tolerances: 60 Hz 380 V - +/-10%
50 Hz 400-415 V - +/-10%

Pump starting frequency should not exceed 15 starts per hour.

For short periods of time, a starting frequency of up to double the recommended is permissible.

Type Key

Ex. SV024CL	S	V	-	02	4	C	L
Type range S = GRUNDFOS submersible wastewater pumps							
Impeller type 1 = Single channel impeller, V = SuperVortex							
Motor specification [] = Non-explosion-proof A = ATEX, 50 Hz, A = Explosion-proof, 60 Hz							
Motor power Motor power in kW							
Motor pole number							
2 2-pole				50 Hz	60 Hz		
4 4-pole				3000	3600		
				1500	1800		
Pump generation [] = 1st generation A = 2nd generation B = 3rd generation, etc. The generation code identifies pumps that differ in design but are similar in power rating							
Head [] = No classification, E = Extra-low, L = Low, M = Medium, H = High, S = Super-high							

The S pumps are identified by the type code stated in the confirmation of order and other documentation supplied with the pump. The code consist of the items shown in the table below.

Material specifications

Part	Material	DIN W.-Nr/EN	AISI/ASTM
Stator housing	Cast iron	EN-JL1040	A48 30
Pump housing	Cast iron	EN-JS1050	A48 30
Impeller S1	Cast iron	EN-JL1040	A48 30
Impeller SV	Cast iron	EN-JL1040	80-55-06
Pump Shaft	Stainless steel	1. 4460	329
Bolts & Nuts	Stainless steel	1. 4436	316
O-rings	NBR	-	-
O-rings Shaft seal	FMK	-	-
Bearings	Heavy-duty Pre lubricated	-	-
Primary shaft seal	SiC/SiC	-	-
Secondary shaft seal	SiC/Carbon	-	-
Lifting bracket	Stainless steel	1. 4408	316
Cables	EPDM, length 10 meter	-	-
Cable Entry	PA or Cast iron	-	-
Surface Protection	Two component Epoxy	-	-
Oil	SAE 10 W 30	-	-

Performance curves

SuperVortex impeller – Range 34

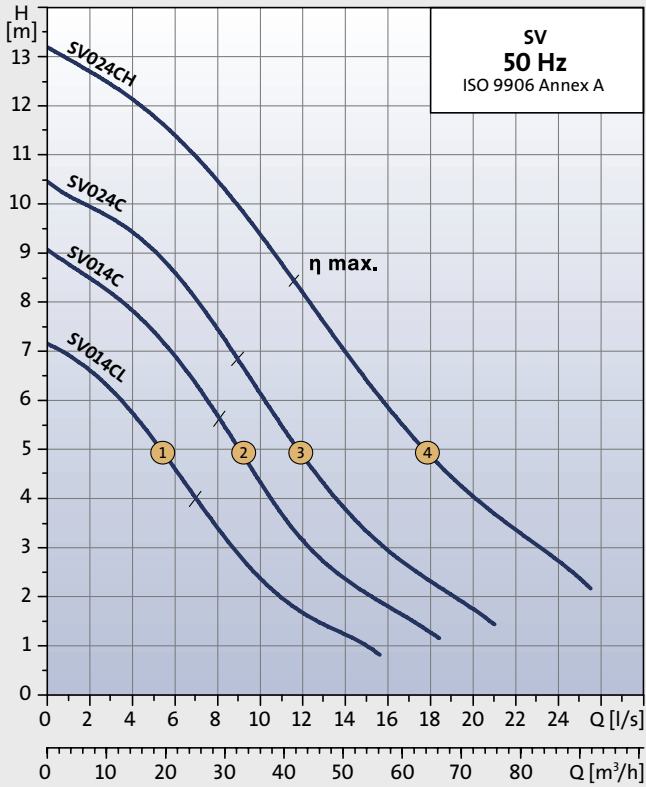

SuperVortex impeller – Range 42

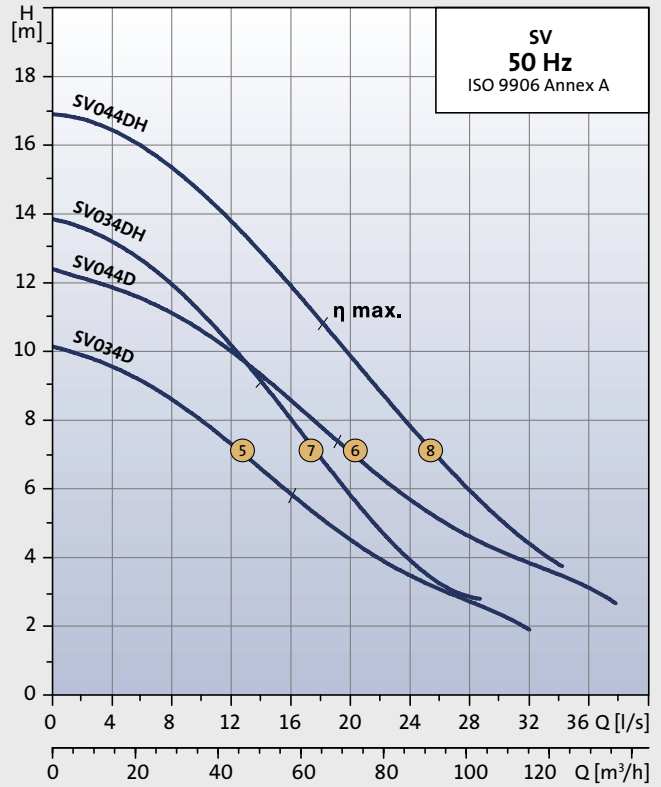

SuperVortex impeller – Range 42

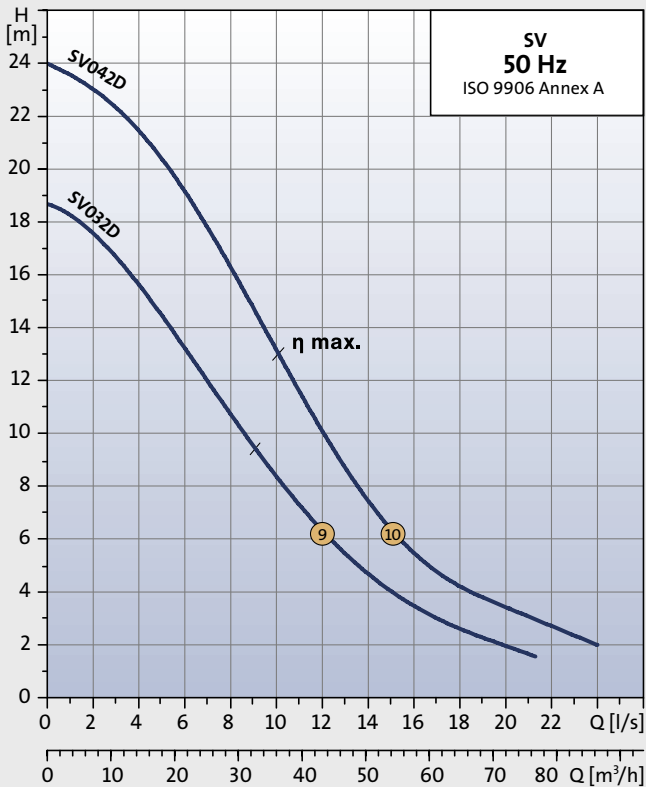

Single Channel impeller – Range 42

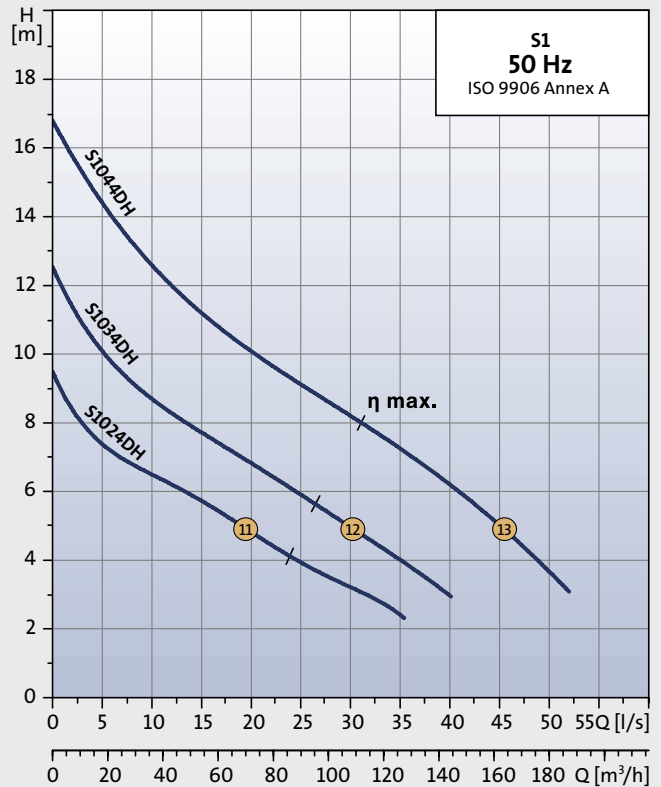

Performance curves

SuperVortex impeller – Range 34

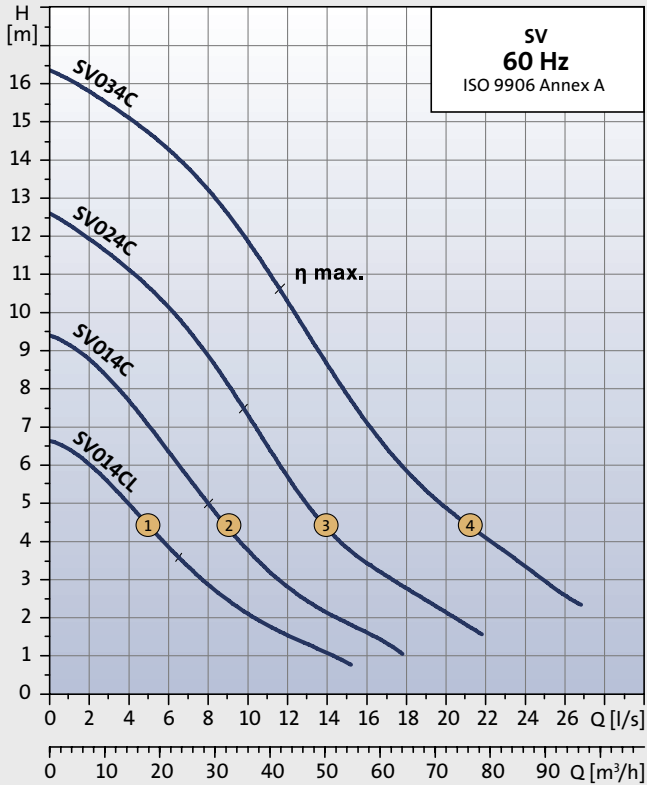

SuperVortex impeller – Range 42

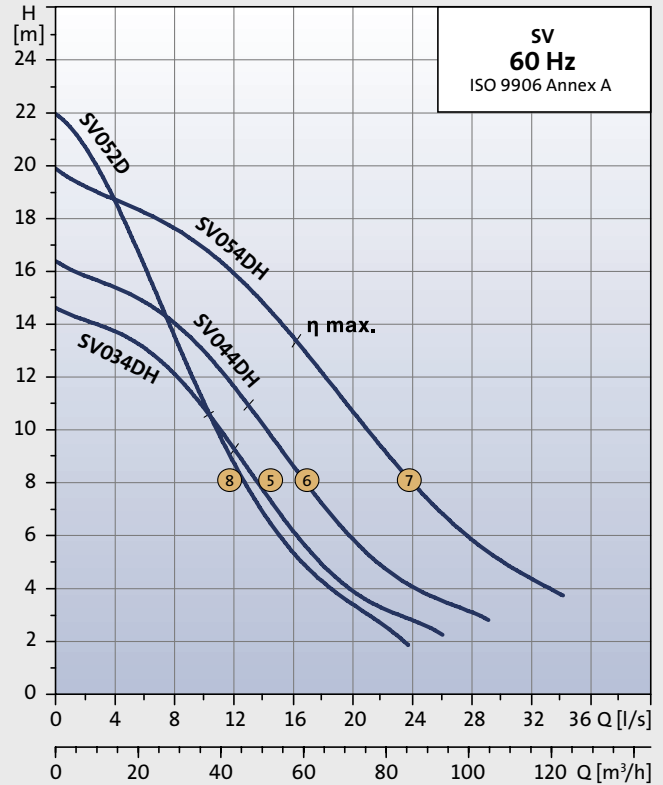

Channel impeller – Range 42

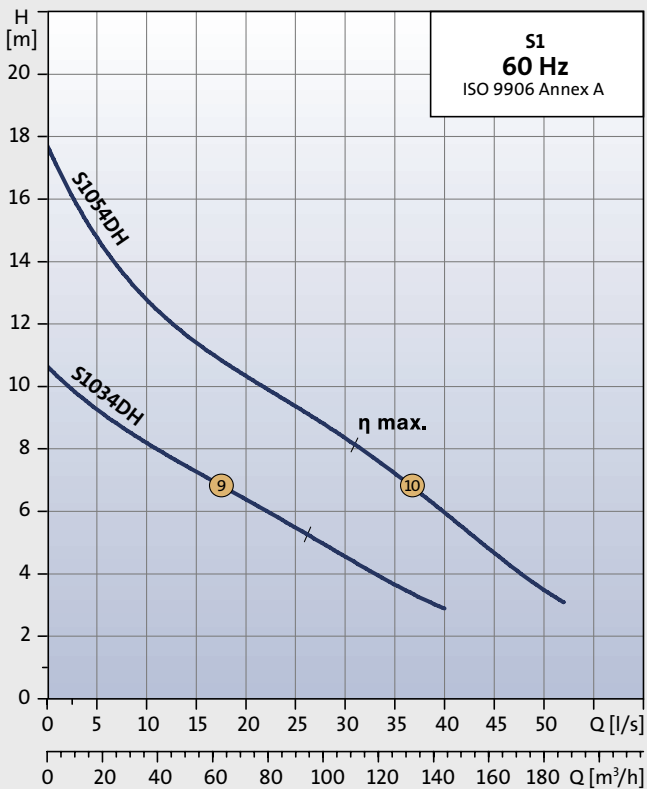

Frame size 34 and 42. Standard and ATEX versions

50 Hz			400 – 415 V													Installation				
Pump type	Pump Curve	Pump Range	Product No. Standard	Product No. ATEX (A) ¹⁾	P ₁ (kW)	P ₂ (kW)	Poles	I _N (A)	I _S (A)	Starting method	Cos FI	Cable length (m)	Impeller type	Max. solids (mm)	Inlet DN	Discharge DN	Weight (kg)	Type S (submerged)	Type C (cooled)	Type D (dry)
SV(A)014CL	1	34	96249067	96249071	2.3	1.7	4	4.4	27.7	Direct on-line (DOL)	0.75	10	SuperVortex	ø80	100	80	74	x	x	x
SV(A)014C	2	34	96249068	96249072	2.3	1.7	4	4.4	27.7		0.75			ø80	100	80	74	x	x	x
SV(A)024C	3	34	96249069	96249073	2.3	1.7	4	4.4	27.7		0.75			ø80	100	80	74	x	x	x
SV(A)024CH*	4	34	96249070	96249074	3.4	2.5	4	5.8	26.7		0.84			ø80	100	80	74	x		
SV(A)034D	5	42	96249118	96249127	3.6	2.9	4	7.0	47.6		0.76			ø80	100	100	105	x	x	x
SV(A)044D*	6	42	96249119	96249128	3.6	2.9	4	7.0	47.6		0.76			ø80	100	100	105	x		
SV(A)034DH	7	42	96249120	96249129	5.3	4.2	4	9.2	46.0		0.84			ø80	100	80	105	x	x	x
SV(A)044DH*	8	42	96249121	96249130	5.3	4.2	4	9.2	46.0		0.84			ø80	100	80	105	x		
SV(A)032D	9	42	96249122	96249131	4.4	3.5	2	7.1	58.2		0.89			ø80	100	80	105	x	x	x
SV(A)042D*	10	42	96249123	96249132	5.9	4.7	2	9.2	58.0		0.92			ø80	100	80	105	x		
S1(A)024DH	11	42	96249115	96249124	2.9	2.9	4	7.0	47.6		0.76		Channel	ø80	100	100	105	x	x	x
S1(A)034DH	12	42	96249116	96249125	2.9	2.9	4	7.0	47.6		0.76			ø80	100	100	105	x	x	x
S1(A)044DH*	13	42	96249117	96249126	5.3	4.2	4	9.2	46.0		0.84			ø80	100	100	105	x		

**) Only to be used for submerged installation. (Version S only).*

1) ATEX Approval IIG / Exd. Temperature Class T4.

60 Hz **)			380 V													Installation				
Pump type	Pump Curve	Pump Range	Product No. Standard	Product No. ATEX (A) ¹⁾	P ₁ (kW)	P ₂ (kW)	Poles	I _N (A)	I _S (A)	Starting method	Cos FI	Cable length (m)	Impeller type	Max. solids (mm)	Inlet DN	Discharge DN	Weight (kg)	Type S (submerged)	Type C (cooled)	Type D (dry)
SV(A)014CL	1	34	96249092	96249104	2.9	2.2	4	5.5	34.1	Direct on-line (DOL)	0.79	10	SuperVortex	ø80	100	80	74	x	x	x
SV(A)014C	2	34	96249095	96249107	2.9	2.2	4	5.5	34.1		0.79			ø80	100	80	74	x	x	x
SV(A)024C	3	34	96249098	96249109	2.9	2.2	4	5.5	34.1		0.79			ø80	100	80	74	x	x	x
SV(A)034C*	4	34	96249101	96249112	4.3	3.2	4	7.7	33.9		0.86			ø80	100	80	74	x		
SV(A)034DH	5	42	96249191	96249212	4.0	3.3	4	8.1	58.3		0.76			ø80	100	80	105	x	x	x
SV(A)044DH	6	42	96249194	96249215	4.0	3.3	4	8.1	58.3		0.76			ø80	100	80	105	x	x	x
SV(A)054DH*	7	42	96249197	96249218	6.0	4.8	2	10.8	58.3		0.84			ø80	100	80	105	x		
SV(A)052D*	8	42	96249200	96249221	6.3	5.2	2	10.5	70.4		0.92			ø80	100	80	105	x		
S1(A)034DH	9	42	96249182	96249203	4.0	3.3	4	8.1	58.3		0.76		Channel	ø80	100	100	105	x	x	x
S1(A)054DH*	10	42	96249188	96249209	6.0	4.8	4	10.8	58.3		0.84			ø80	100	100	105	x		

**) Only to be used for submerged installation. (Version S only).*

****) Also available as 220 and 460 V in 60 Hz version on request.*

1) ATEX Approval IIG / Exd. Temperature Class T4.

Dimensions and installation

Dimensions, auto-coupling installation

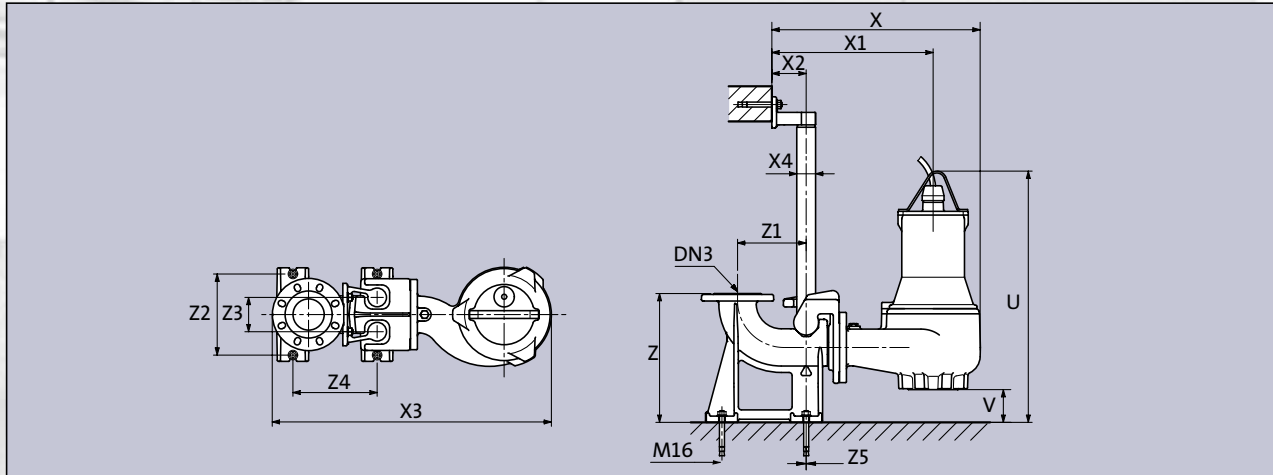

50 Hz	Dimensions [mm]															
Pump type	Pump Range	U	V	X	X1	X2	X3	X4	Z	Z1	Z2	Z3	Z4	Z5	DN3	Weight
SV(A)014CL	34	775	100	510	358	81	700	1½"	345	171	220	95	160	13	80	74
SV(A)014C	34	775	100	510	358	81	700	1½"	345	171	220	95	160	13	80	74
SV(A)024C	34	775	100	510	358	81	700	1½"	345	171	220	95	160	13	80	74
SV(A)024C	34	775	100	510	358	81	700	1½"	345	171	220	95	160	13	80	74
SV(A)034D	42	805	105	670	520	110	895	2"	413	220	260	110	270	0	100	105
SV(A)044D	42	805	105	670	520	110	895	2"	413	220	260	110	270	0	100	105
SV(A)034DH	42	745	80	645	465	81	840	1½"	345	171	220	95	160	13	80	105
SV(A)044DH	42	745	80	645	465	81	840	1½"	345	171	220	95	160	0	80	105
SV(A)032D	42	770	90	575	425	81	770	1½"	345	171	220	95	160	13	80	105
SV(A)042D	42	770	90	575	425	81	770	1½"	345	171	220	95	160	13	80	105
S1(A)024DH	42	780	85	685	520	110	910	2"	413	220	260	110	270	0	100	105
S1(A)034DH	42	780	85	685	520	110	910	2"	413	220	260	110	270	0	100	105
S1(A)044DH	42	780	85	685	520	110	910	2"	413	220	260	110	270	0	100	105

60 Hz	Dimensions [mm]															
Pump type	Pump Range	U	V	X	X1	X2	X3	X4	Z	Z1	Z2	Z3	Z4	Z5	DN3	Weight
SV(A)014CL	34	775	100	510	358	81	700	1½"	345	171	220	95	160	13	80	74
SV(A)014C	34	775	100	510	358	81	700	1½"	345	171	220	95	160	13	80	74
SV(A)024C	34	775	100	510	358	81	700	1½"	345	171	220	95	160	13	80	74
SV(A)034CH	34	775	100	510	358	81	700	1½"	345	171	220	95	160	13	80	74
SV(A)034DH	42	745	80	645	465	81	840	1½"	345	171	220	95	160	13	80	105
SV(A)044DH	42	745	80	645	465	81	840	1½"	345	171	220	95	160	13	80	105
SV(A)054DH	42	745	80	645	465	81	840	1½"	345	171	220	95	160	0	80	105
SV(A)052D	42	770	90	575	425	81	770	1½"	345	171	220	95	160	13	80	105
S1(A)034DH	42	780	85	685	520	110	910	2"	413	220	260	110	270	0	100	105
S1(A)054DH	42	780	85	685	520	110	910	2"	413	220	260	110	270	0	100	105

Dimensions, free-standing without accessories

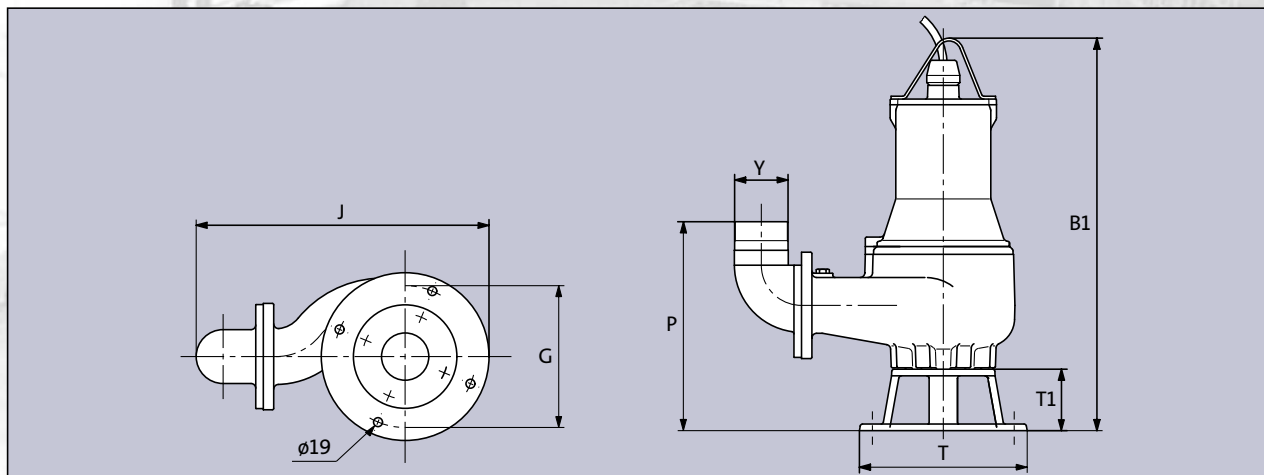

50 Hz	Dimensions [mm]								
Pump type	Pump Range	B1	G	J	P	T	T1	Y	Weight
SV(A)014CL	34	805	300	515	405	355	130	R3"	74
SV(A)014C	34	805	300	515	405	355	130	R3"	74
SV(A)024C	34	805	300	515	405	355	130	R3"	74
SV(A)024CH	34	805	300	515	405	355	130	R3"	74
SV(A)034D	42	830	300	620	445	355	130	R4"	105
SV(A)044D	42	830	300	620	445	355	130	R4"	105
SV(A)034DH	42	805	300	600	425	355	130	R3"	105
SV(A)044DH	42	805	300	600	425	355	130	R3"	105
SV(A)032D	42	805	300	560	415	355	130	R3"	105
SV(A)042D	42	805	300	560	415	355	130	R3"	105
S1(A)024DH	42	825	300	620	465	355	130	R4"	105
S1(A)034DH	42	825	300	620	465	355	130	R4"	105
S1(A)044DH	42	825	300	620	465	355	130	R4"	105

60 Hz	Dimensions [mm]								
Pump type	Pump Range	B1	G	J	P	T	T1	Y	Weight
SV(A)014CL	34	805	300	515	405	355	130	R3"	74
SV(A)014C	34	805	300	515	405	355	130	R3"	74
SV(A)024C	34	805	300	515	405	355	130	R3"	74
SV(A)034CH	34	805	300	515	405	355	130	R3"	74
SV(A)034DH	42	805	300	600	425	355	130	R3"	105
SV(A)044DH	42	805	300	600	425	355	130	R3"	105
SV(A)054DH	42	805	300	600	425	355	130	R3"	105
SV(A)052D	42	805	300	560	415	355	130	R3"	105
S1(A)034DH	42	825	300	620	465	355	130	R4"	105
S1(A)054DH	42	825	300	620	465	355	130	R4"	105

Dimensions and installation

Dimensions, dry vertical on base stand

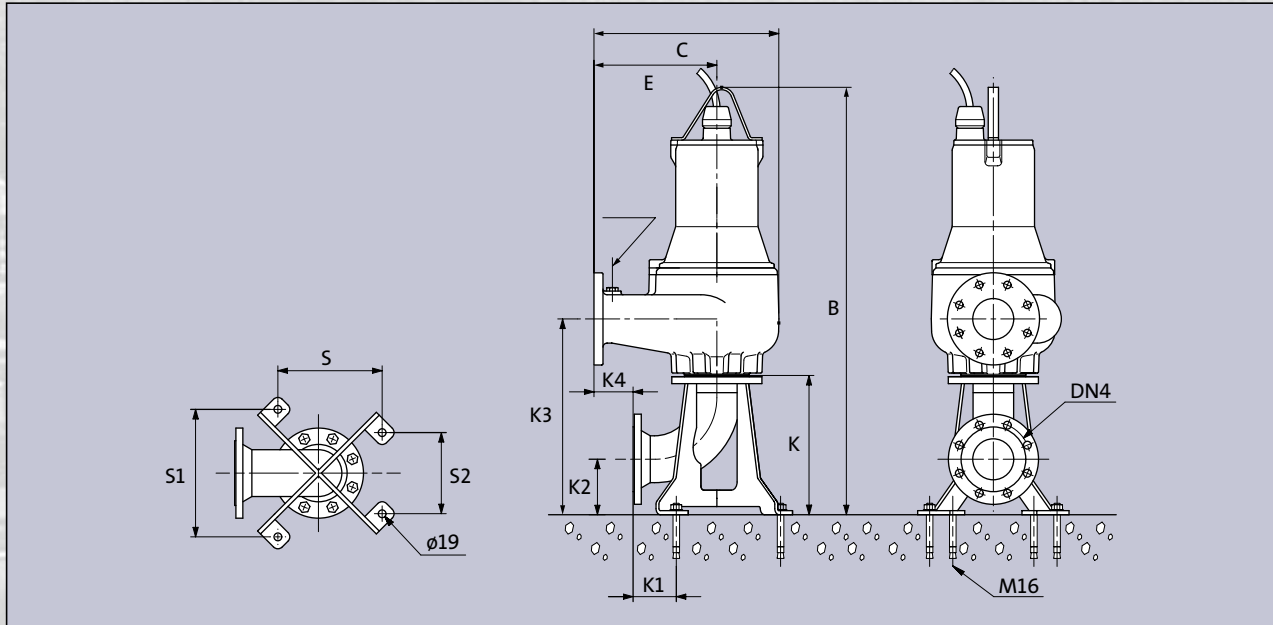

50 Hz		Dimensions [mm]												
Pump type	Pump Range	B	C	E	K	K1	K2	K3	K4	S	S1	S2	DN4	Weight
SV(A)014CL	34	1020	345	219	341	106	136	443	15	255	311	198	100	74
SV(A)014C	34	1020	345	219	341	106	136	443	15	255	311	198	100	74
SV(A)024C	34	1020	345	219	341	106	136	443	15	255	311	198	100	74
SV(A)034D	42	1045	455	300	341	106	136	478	95	255	311	198	100	105
SV(A)034DH	42	1010	480	300	341	106	136	463	95	255	311	198	100	105
SV(A)032D	42	1025	415	260	341	106	136	463	55	255	311	198	100	105
S1(A)024DH	42	1040	470	300	341	106	136	498	95	255	311	198	100	105
S1(A)034DH	42	1040	470	300	341	106	136	498	95	255	311	198	100	105

60 Hz		Dimensions [mm]												
Pump type	Pump Range	B	C	E	K	K1	K2	K3	K4	S	S1	S2	DN4	Weight
SV(A)014CL	34	1020	345	219	341	106	136	443	15	255	311	198	100	74
SV(A)014C	34	1020	345	219	341	106	136	443	15	255	311	198	100	74
SV(A)024C	34	1020	345	219	341	106	136	443	15	255	311	198	100	74
SV(A)034DH	42	1010	480	300	341	106	136	463	95	255	311	198	100	105
SV(A)044DH	42	1010	480	300	341	106	136	463	95	255	311	198	100	105
S1(A)034DH	42	1040	470	300	341	106	136	498	95	255	311	198	100	105



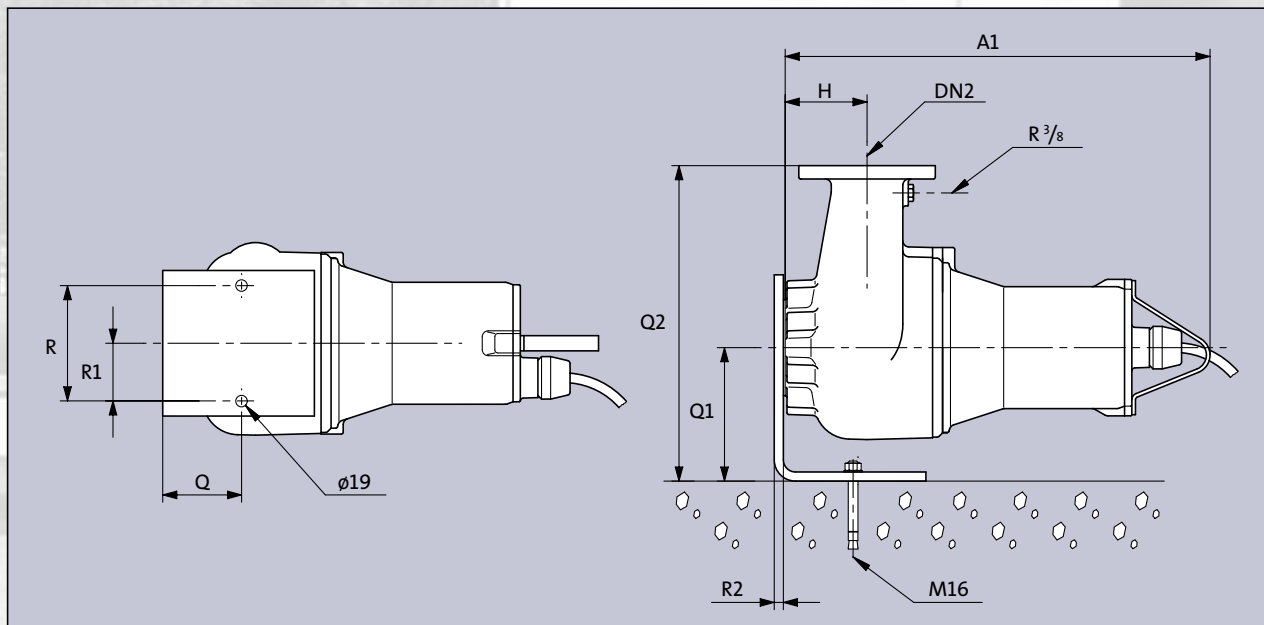



Dimensions, dry horizontal installation



50 Hz		Dimensions [mm]									
Pump type	Pump Range	A1	H	Q	Q1	Q2	R	R1	R2	DN2	Weight
SV(A)014CL	34	675	100	130	220	439	190	95	15	80	74
SV(A)014C	34	675	100	130	220	439	190	95	15	80	74
SV(A)024C	34	675	100	130	220	439	190	95	15	80	74
SV(A)034D	42	700	135	190	220	520	190	95	15	100	105
SV(A)034DH	42	665	120	130	220	520	190	95	15	80	105
SV(A)032D	42	680	110	130	220	480	190	95	15	80	105
S1(A)024DH	42	695	155	130	220	520	190	95	15	100	105
S1(A)034DH	42	695	155	130	220	520	190	95	15	100	105

60 Hz		Dimensions [mm]									
Pump type	Pump Range	A1	H	Q	Q1	Q2	R	R1	R2	DN2	Weight
SV(A)014CL	34	675	100	130	220	439	190	95	15	80	74
SV(A)014C	34	675	100	130	220	439	190	95	15	80	74
SV(A)024C	34	675	100	130	220	439	190	95	15	80	74
SV(A)034DH	42	665	120	130	220	520	190	95	15	80	105
SV(A)044DH	42	665	120	130	220	520	190	95	15	80	105
S1(A)034DH	42	665	155	130	220	520	190	95	15	100	105

Accessories

Pos.	Picture	Description	Dimensions	DN 80	DN 100	Product number
1		Auto-coupling system complete with guide claw, base plate and upper guide-rail holder. With gaskets and bolts. Cast iron, epoxy-coated.	DN 80	•		96090993
			DN 80/DN 100	•		96102240
			DN 100		•	96090994
2		Ring stand with flanged 90° elbow and hose connection. With bolts, nuts, gaskets and anchor bolts. Cast iron, epoxy-coated.	DN 80/DN 80/3"	•		96102254
			DN 100/DN 80/3"	•		96102313
			DN 100/DN 100/4"		•	96102255
		Ring stand with flanged 90° elbow and outside thread connection. With bolts, nuts, gaskets and anchor bolts. Cast iron, epoxy-coated.	DN 80/DN 80/R 3	•		96102381
			DN 100/DN 80/R 3	•		96102382
			DN 100/DN 100/R4		•	96102383
3		Base stand for vertical dry installation, including 90° elbow. With bolts, gaskets and anchor bolts. Galvanized steel.	DN 100		•	96102259
4		Bracket for horizontal dry installation. With bolts, gaskets and anchor bolts. Galvanized steel.	DN 100		•	96255509
5		10° adaptor with lift function for Grundfos base plate UV 35579 incl. guide claw, bolt, nuts and gasket.		•		96572290
					•	96294872
6		Adaptor for Grundfos base plate UV 35586 B incl. guide claw, bolt, nuts and gasket.		•		96572291
					•	96572292
7		Lifting chain with shackle. With certificates. Galvanized steel.	6 m	•	•	96497465
8		AMD.07.18.1410 mixer for flushing in pump sump.				Contact Grundfos

The Grundfos wastewater range

S range 5 – 29 kW

Brochure covers the Grundfos range of submersible channel-impeller pumps from 5 kW up to 21 kW and Super-Vortex pumps up to 29 kW. All designed for handling unscreened raw sewage. Available in 50 Hz and 60 Hz versions.



S range 15 – 155 kW

Brochure covers the Grundfos range of sewage pumps from 15 kW up to 155 kW for handling of raw sewage in heavy-duty applications. Available in 50 Hz and 60 Hz versions.



S/SA ranges up to 520 kW

Brochure covers the Grundfos range of super-heavy-duty channel pumps, axial flow pumps, and propeller pumps from 7.5 kW up to 520 kW.

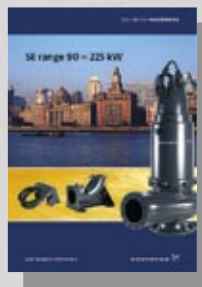

SE range 90–220 kW

Brochure covers the Grundfos range of updated heavy-duty submersible sewage pumps. Includes descriptions of the new built-in sensors.



SRP range 3.0 – 24 kW

Brochure covers the Grundfos range of SRP submersible recirculation pumps for wastewater treatment plants and flood control. Available in 50 Hz and 60 Hz versions.



SEN range 1.0 – 21 kW

Brochure covers the Grundfos range of heavy-duty stainless steel pumps (SEN) for aggressive and corrosive environments.



Multilift M, MD, MDV, and MD1 ranges

Brochure covers Grundfos lifting stations for individual as well as multi-user applications.

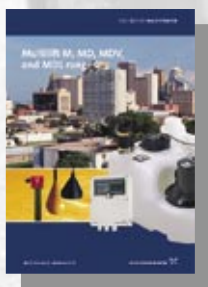

LC/LCD Ranges – level controllers

Brochure covers the Grundfos range of controls for the wastewater pumping systems.



AMD, AMG, and AFG ranges

Brochure covers the new range of mixers and flowmakers for optimal control of liquids and solids throughout the wastewater treatment process.



SEG range 0.9 – 4.0 kW

Brochure covers the Grundfos range of sewage grinder pumps (SEG) for pumping of wastewater with toilet discharge.



DP, EF, SE1 and SEV ranges 0.6 – 2.6 kW

Brochure covers the Grundfos range of submersible channel-impeller and Super-Vortex-impeller pumps from 0.6 to 2.6 kW. Designed for handling drainage, effluent and sewage from private dwellings.



Prefabricated pumping stations

Brochure covers the Grundfos range of prefabricated pumping stations for collecting and removing drainwater, surface water, domestic and industrial wastewater and sewage.

SE1 and SEV ranges 1.1 – 11 kW

This brochure describes the innovative SEV/SE1 pump lines. Fitted with Super-Vortex or single-channel impellers, these pumps can meet approximately 80% of all wastewater pumping needs.

