

MTA(H) curve charts and technical data

MTA 30

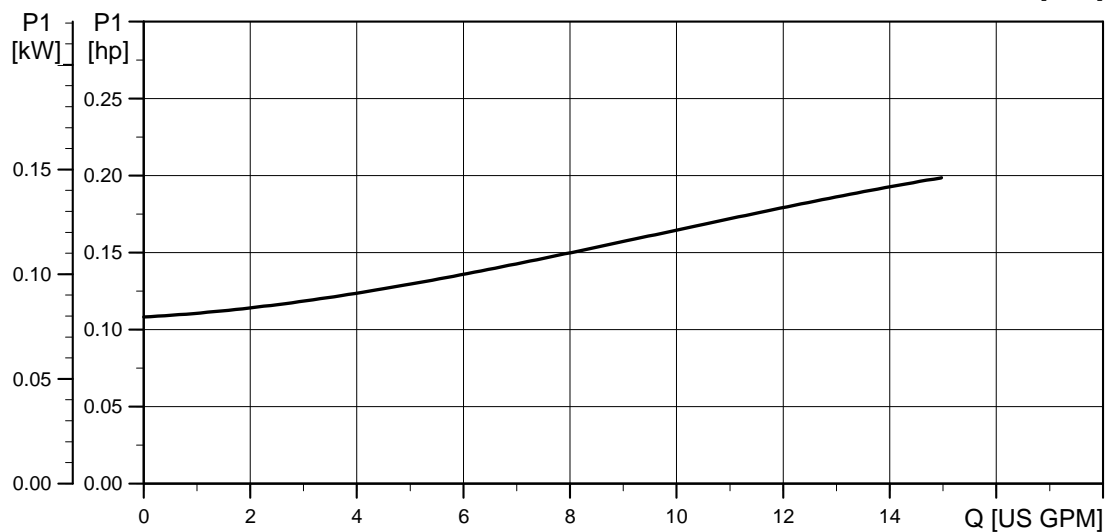

Dimensional sketches

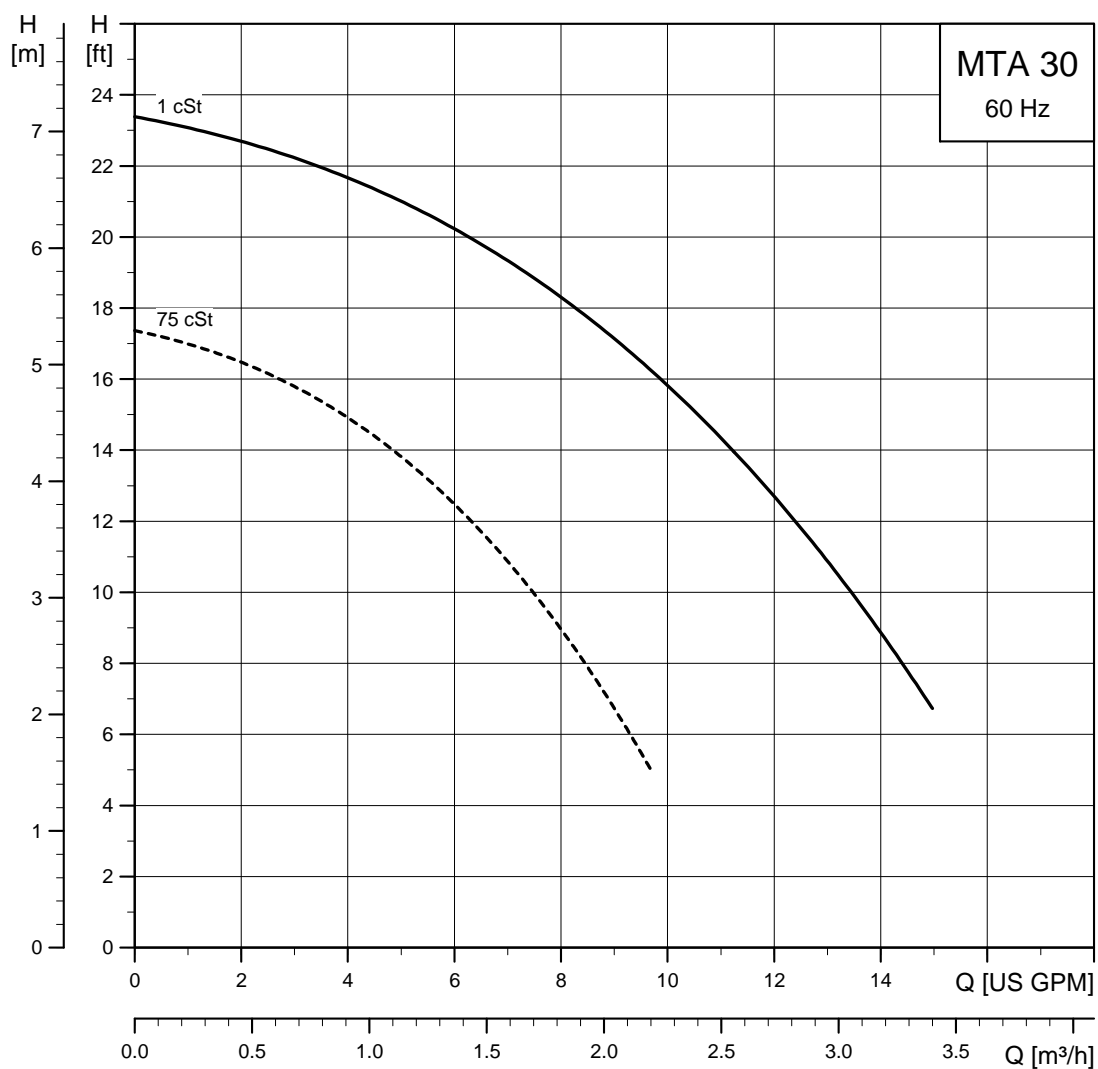
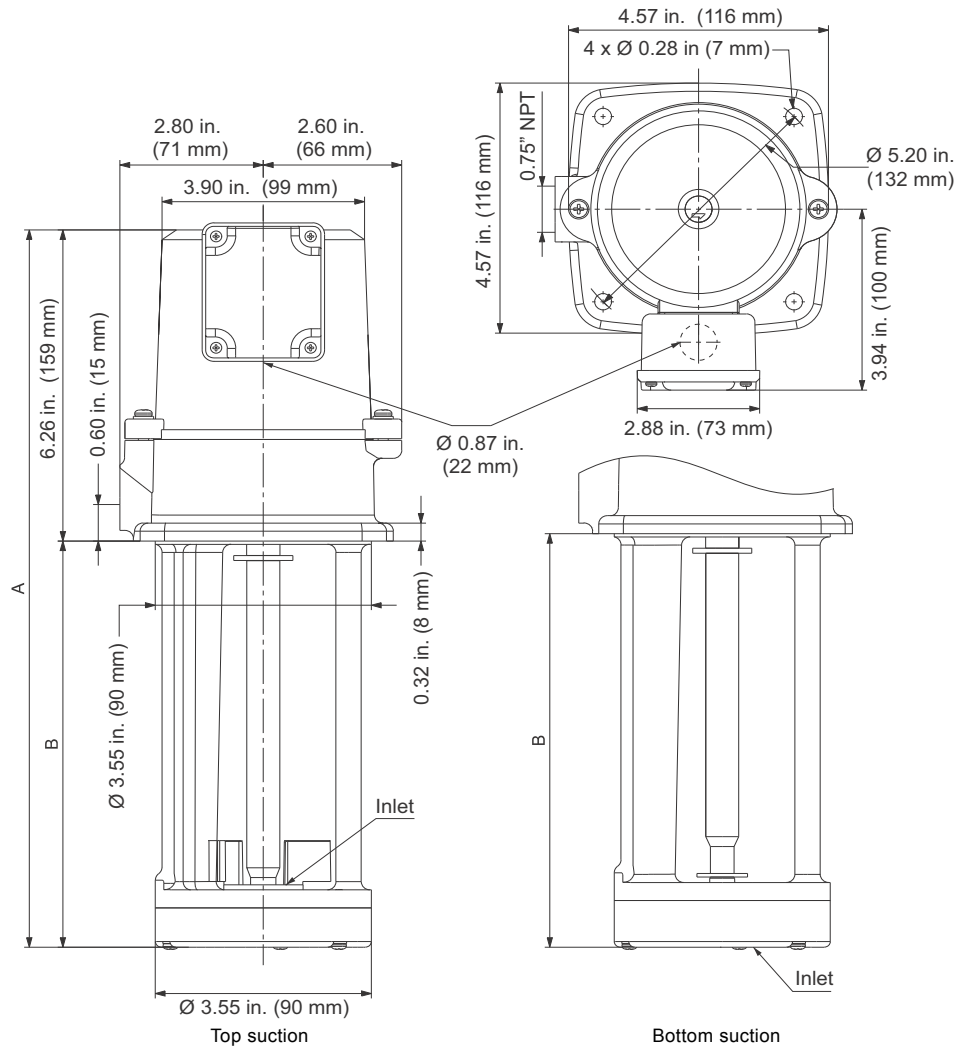

TM05 4993 3112

Dimensions and weights

Pump type	Suction	A [in. (mm)]	B [in. (mm)]	Ship weight [lb]
MTA 30-150	Top	12.17 (309)	5.91 (150)	17
MTA 30-150	Bottom	12.29 (312)	6.03 (153)	17

Electrical data

Voltage	Frequency [Hz]	P1 [W]	I _{1/1} [A]	I _{max} [A]	I _{start} / I _{1/1} [A]	Cos φ
3 x 200Δ V	60	145	0.5	0.58 - 0.58	4.8 - 5.2	0.84 - 0.76
3 x 220-240Δ/380-440Y V	60	142	0.41 / 0.24 - 0.22	0.47 / 0.28 - 0.25	4.8 - 5.2	0.91 - 0.83