

TP 80-XX

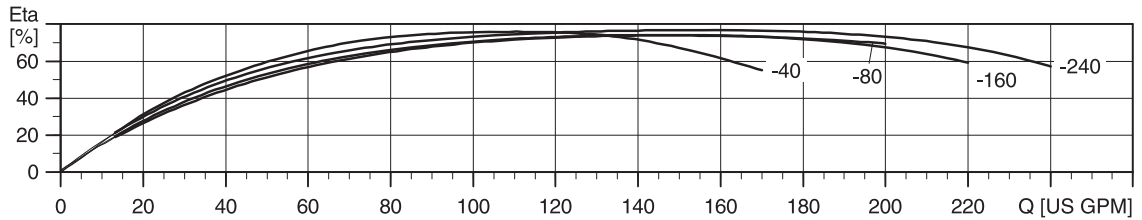

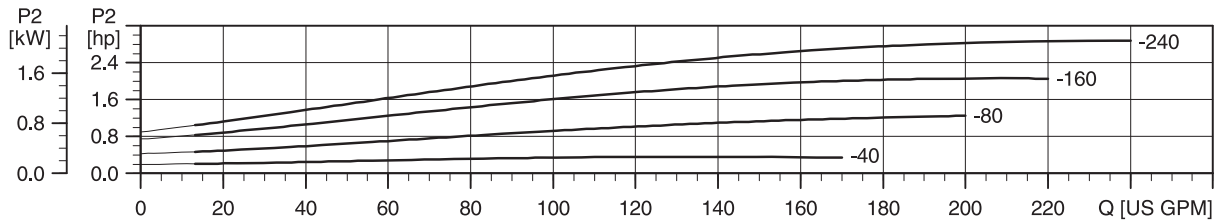
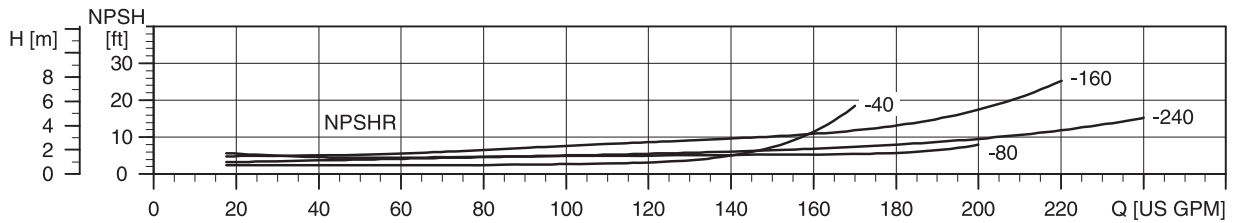
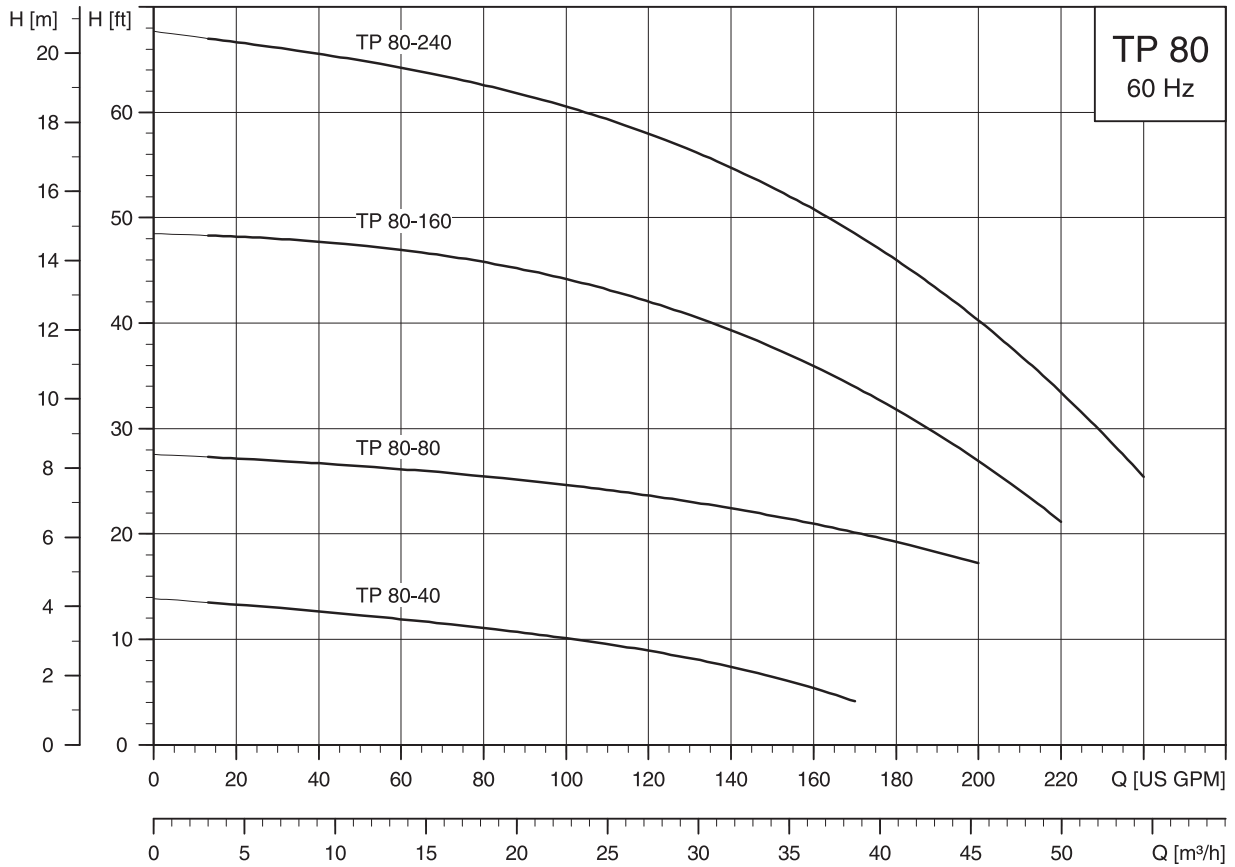
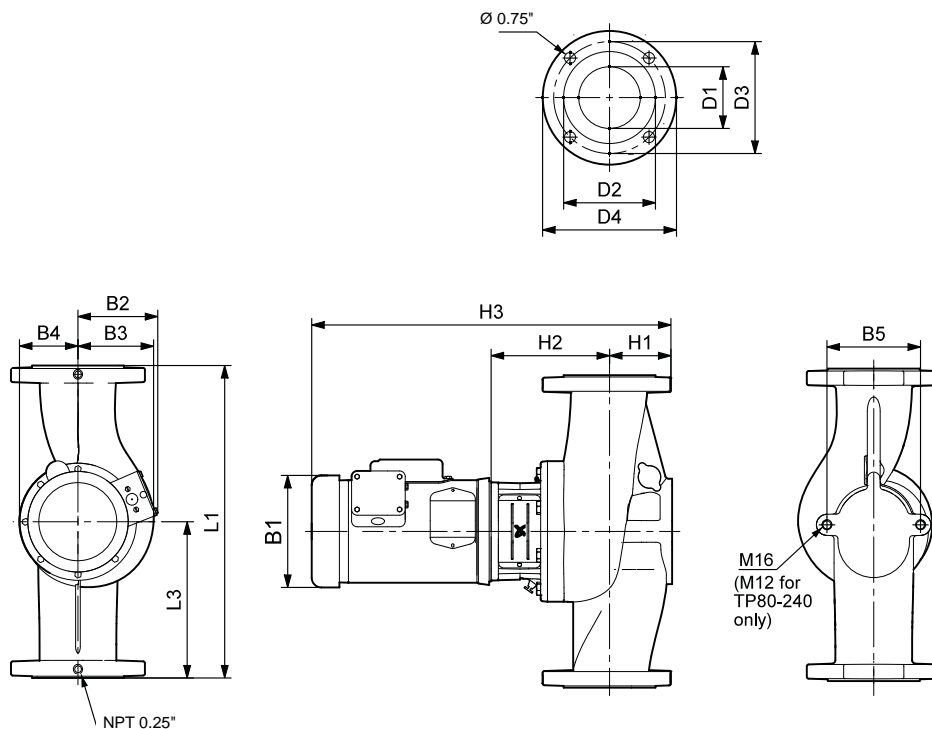

TMO 7769 4806

Dimensions and weights TP 80-XX

Pump type	Hp	Ph	Dimensions [inches (mm)]																	Net weight [lbs]
			L1	L3	B1	B2	B3	B4	B5	H1	H2	H3	D1	D2	D3	D4	D6	D7		
TP 80-40/4	0.5	1	19 (483)	9.5 (241)	6.19 (157)	5.19 (132)	5 (127)	4 (102)	6.3 (160)	3.82 (97)	6.33 (161)	20.06 (510)	3.19 (81)	5 (127)	6 (152)	7.5 (191)	-	-	121	
	0.5	3	19 (483)	9.5 (241)	6.19 (157)	5.19 (132)	5 (127)	4 (102)	6.3 (160)	3.82 (97)	6.33 (161)	19.44 (494)	3.19 (81)	5 (127)	6 (152)	7.5 (191)	-	-	116	
TP 80-80/4	1.5	1	19 (483)	9.5 (241)	7.19 (183)	5.74 (146)	5 (127)	4 (102)	6.3 (160)	3.82 (97)	6.33 (161)	22.21 (564)	3.19 (81)	5 (127)	6 (152)	7.5 (191)	-	-	121	
	1.5	3	19 (483)	9.5 (241)	7.19 (183)	5.74 (146)	5 (127)	4 (102)	6.3 (160)	3.82 (97)	6.33 (161)	21.32 (543)	3.19 (81)	5 (127)	6 (152)	7.5 (191)	-	-	120	
TP 80-160/2	3	1	19 (483)	9.5 (241)	8.6 (218)	6.87 (175)	4 (102)	4 (102)	6.3 (160)	3.82 (97)	7.04 (179)	25.26 (642)	3.19 (81)	5 (127)	6 (152)	7.5 (191)	-	-	145	
	3	3	19 (483)	9.5 (241)	7.01 (178)	4.33 (110)	4 (102)	4 (102)	6.3 (160)	3.82 (97)	7.04 (179)	24.09 (612)	3.19 (81)	5 (127)	6 (152)	7.5 (191)	-	-	152	
TP 80-240/2	3	1	19 (483)	9.5 (241)	8.6 (218)	6.87 (175)	4 (102)	4 (102)	4.72 (120)	3.82 (97)	6.84 (174)	25.06 (637)	3.19 (81)	5 (127)	6 (152)	7.5 (191)	-	-	144	
	3	3	19 (483)	9.5 (241)	7.01 (178)	4.33 (110)	4 (102)	4 (102)	4.72 (120)	3.82 (97)	6.84 (174)	23.89 (607)	3.19 (81)	5 (127)	6 (152)	7.5 (191)	-	-	143	

Note: For information about motor data, see page 25.

Technical data

Flow range:	12-240 U.S. gpm
Head range:	4-67 ft
Maximum working pressure:	145 psi (10 bar)
Temperature range:	5 °F (-15 °C) to 284 °F (140 °C)
Max ambient air temperature:	104 °F (40 °C)
Motors:	TEFC-Standard, ODP-Optional
Flanges:	3" ANSI 125 lb., R.F.